

**SECTION VIEW OF CANOPY**

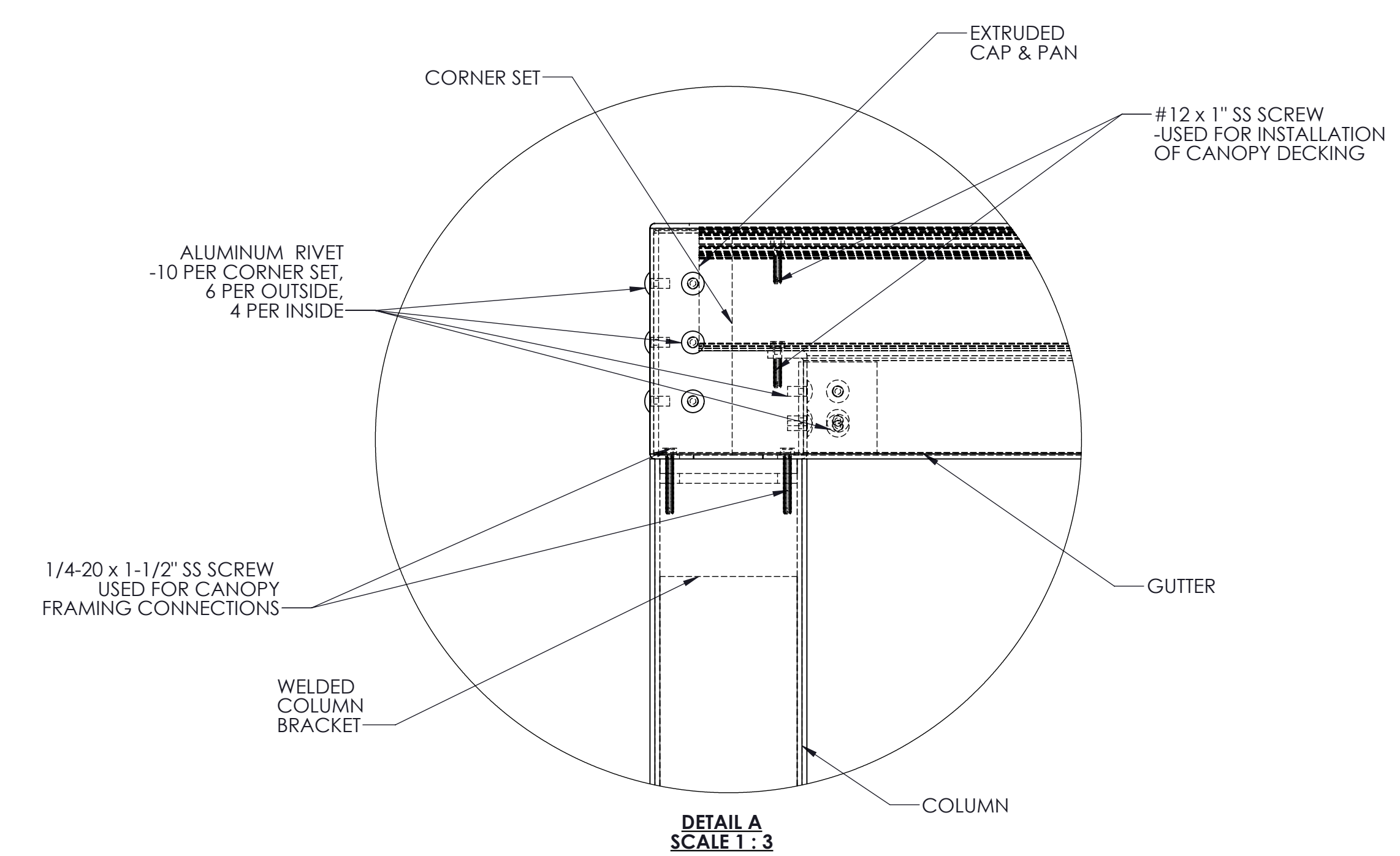

**DETAIL A  
SCALE 1:3**

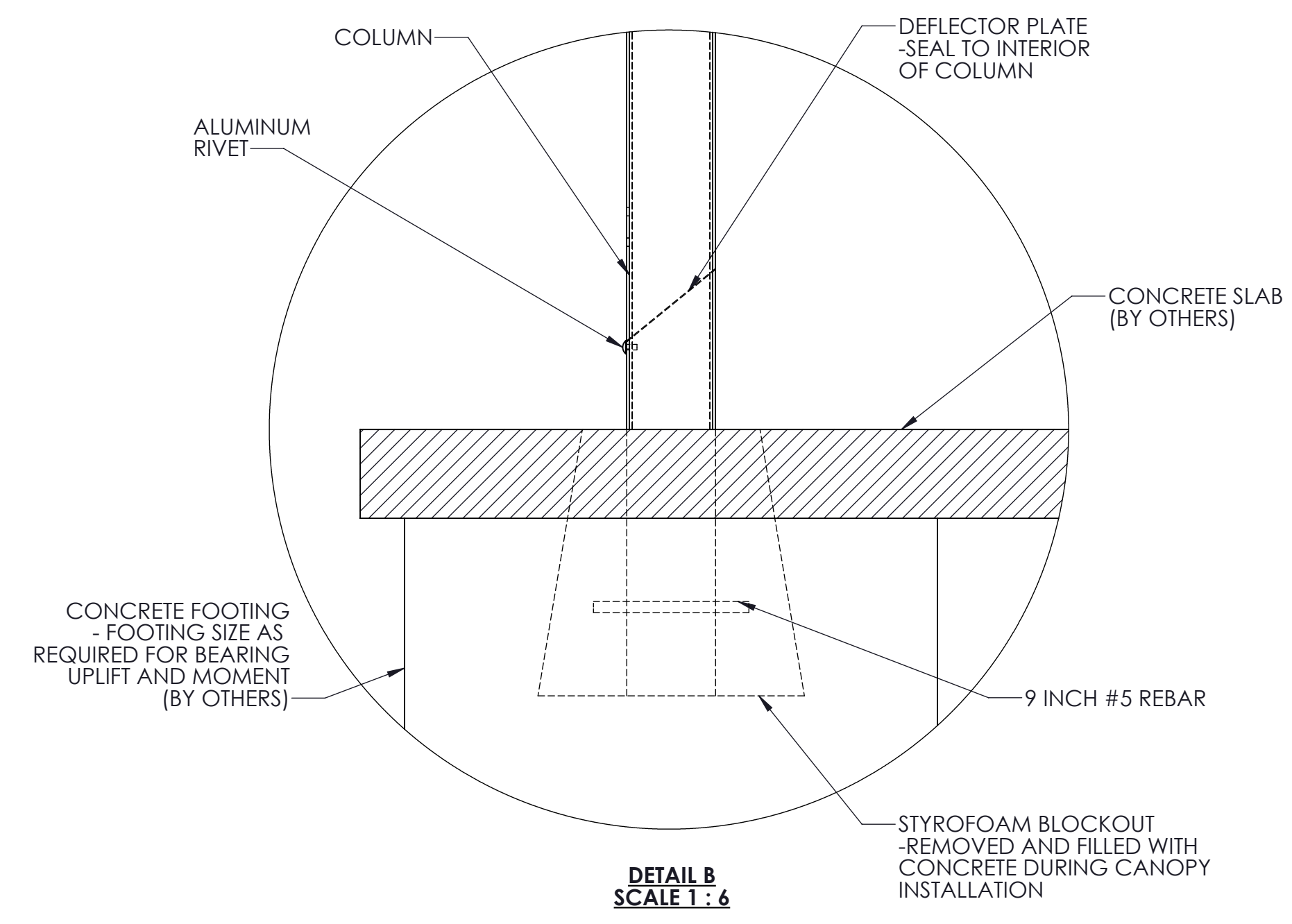

**DETAIL B  
SCALE 1:6**

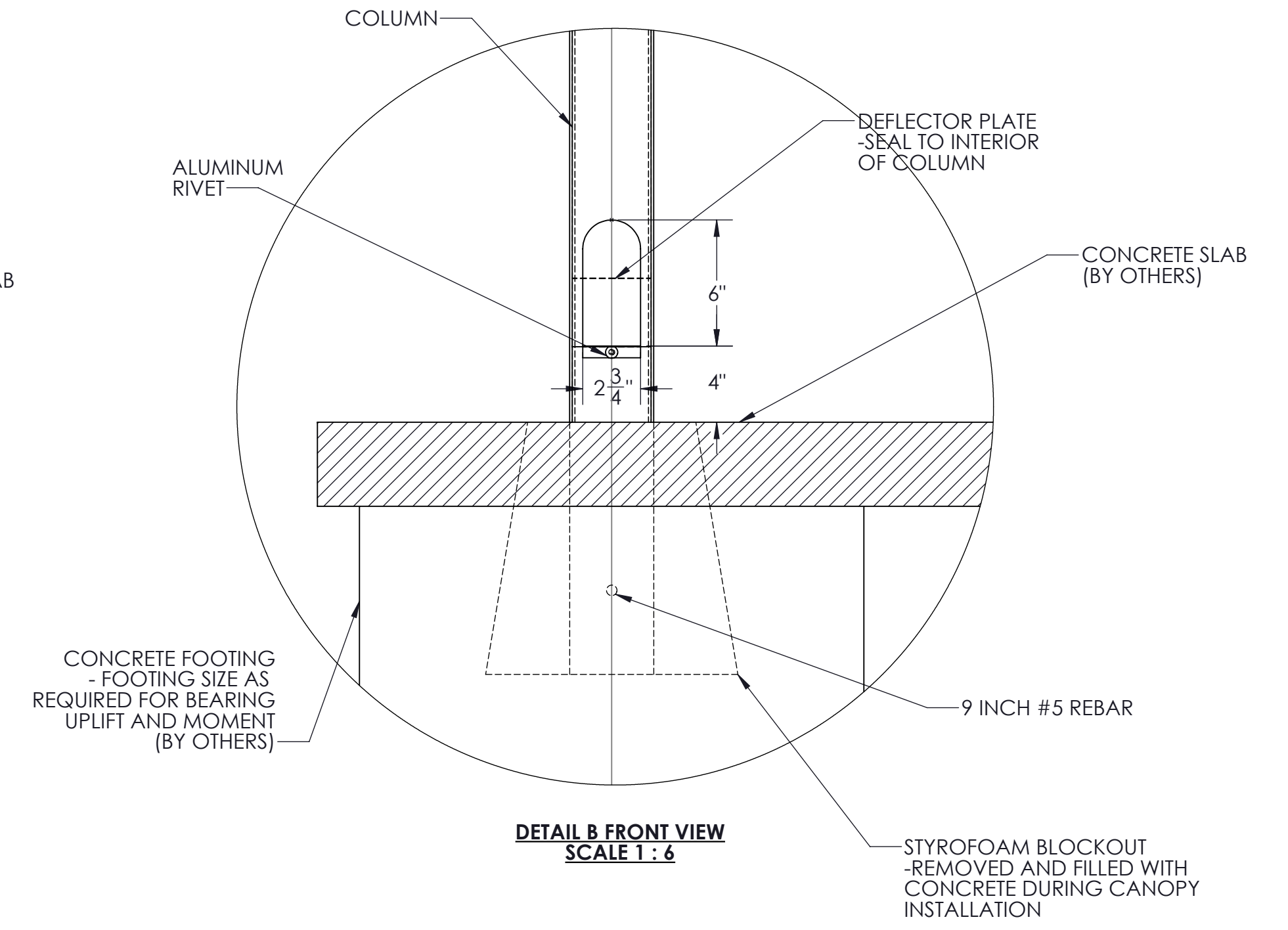

**DETAIL B FRONT VIEW  
SCALE 1:6**

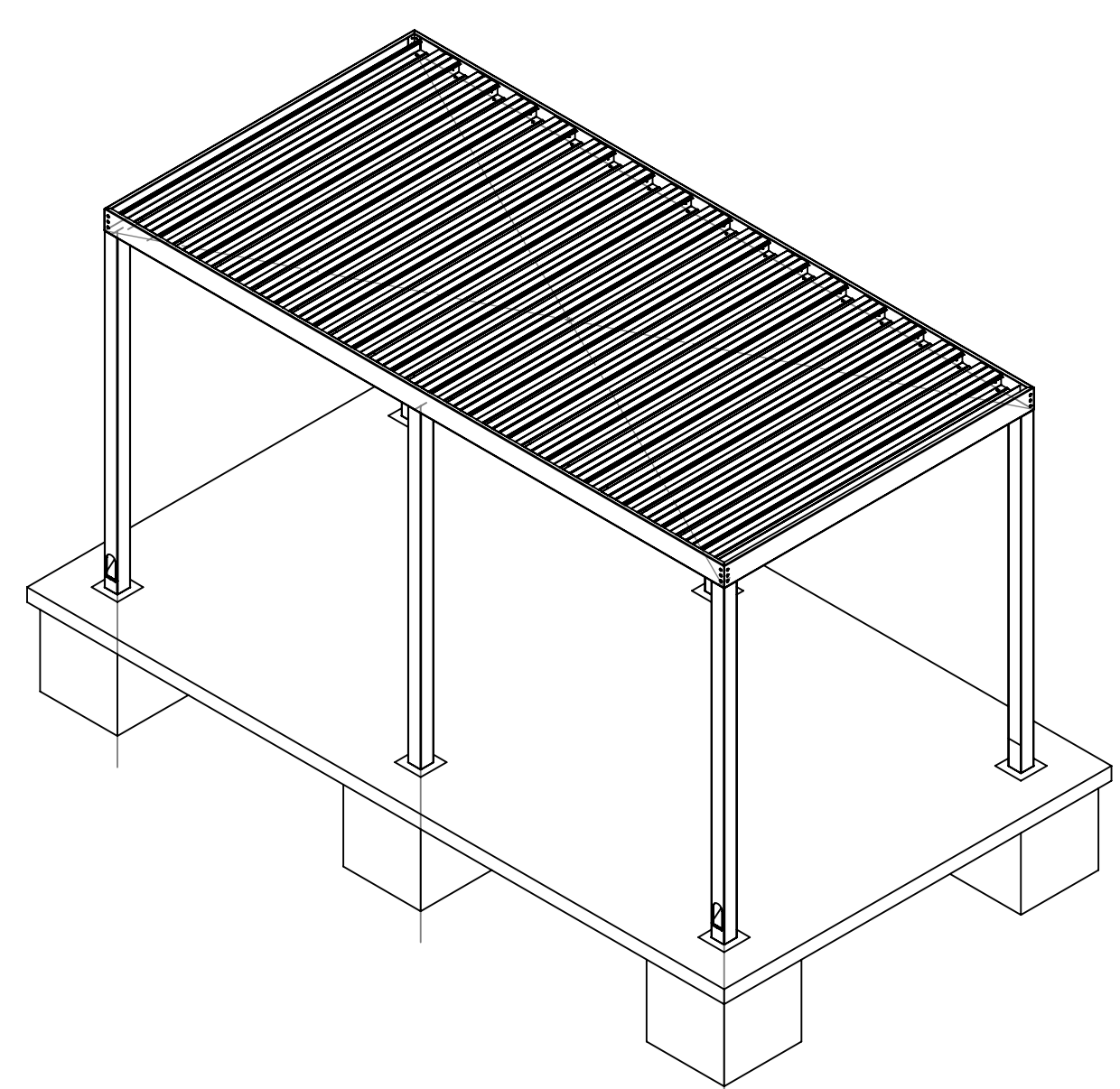

**ISOMETRIC VIEW OF CANOPY**

**SPECIFICATIONS**  
Section 107300 - Aluminum Walkway Covers

**1.01 General Description of Work:**  
A. Work in this section shall include design and fabrication of pre-engineered aluminum canopies.  
B. Canopies are to be fabricated and installed according to approved shop drawings.

**1.02 Design Criteria:**  
A. International Building Code 2015  
B. ASCE 7-10  
C. Aluminum Design Manual 2015  
D. Local governing codes and standards for site location

**1.03 Materials:**  
A. All materials shall be extruded from aluminum unless indicated otherwise on the drawing.  
B. Material sizes shall meet or exceed the design criteria on 1.02

**1.04 Finishes:**  
A. Factory applied baked enamel to comply with AAMA 2603  
B. Color selected from manufacturers standard colors

**1.05 Manufacturers:**  
A. Mitchell Metals, LLC - www.mitchellmetals.net - 770-431-7300  
B. Dittmer - www.dittdeck.com - 407-699-1755  
C. See Specifications 2.1-C for conditions of equivalent systems by other manufacturers.

**NO BEAMS ONLY RECOMMENDED  
IF BOTH SIDES OF CANOPY ARE  
ALLOWED TO DRAIN**

- NOTES:
- [DC] = DRAINING COLUMN (IF APPLICABLE)
  - CANOPY WIDTH RECOMMENDED NOT TO EXCEED 13'-0"
  - COLUMN HEIGHT RECOMMENDED NOT TO EXCEED 12'-0" OR WIDTH OF CANOPY, WHICH EVER IS LOWER
  - ALL FASTENERS TO BE 300 SERIES STAINLESS STEEL OR ALUMINUM

JOB NAME: <b>Aluminum Walkway Covers</b>	
TITLE: <b>SHORTWAYS WITHOUT BEAMS</b>	
REVISION # :	
DATE: 8/16/2017	SHEET 1 OF 1

STAMP