

SECTION VIEW OF CANOPY

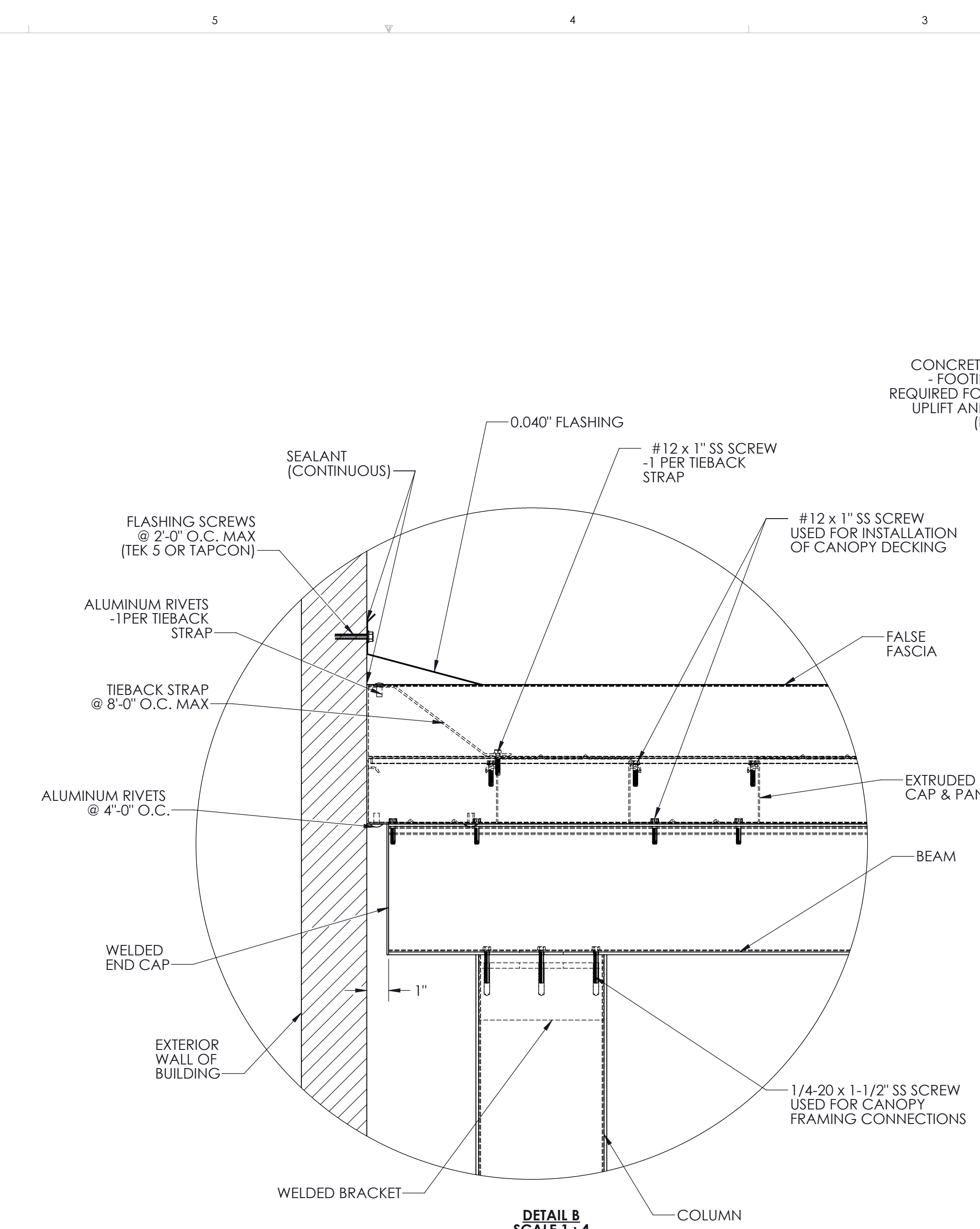

DETAIL B SCALE 1:4

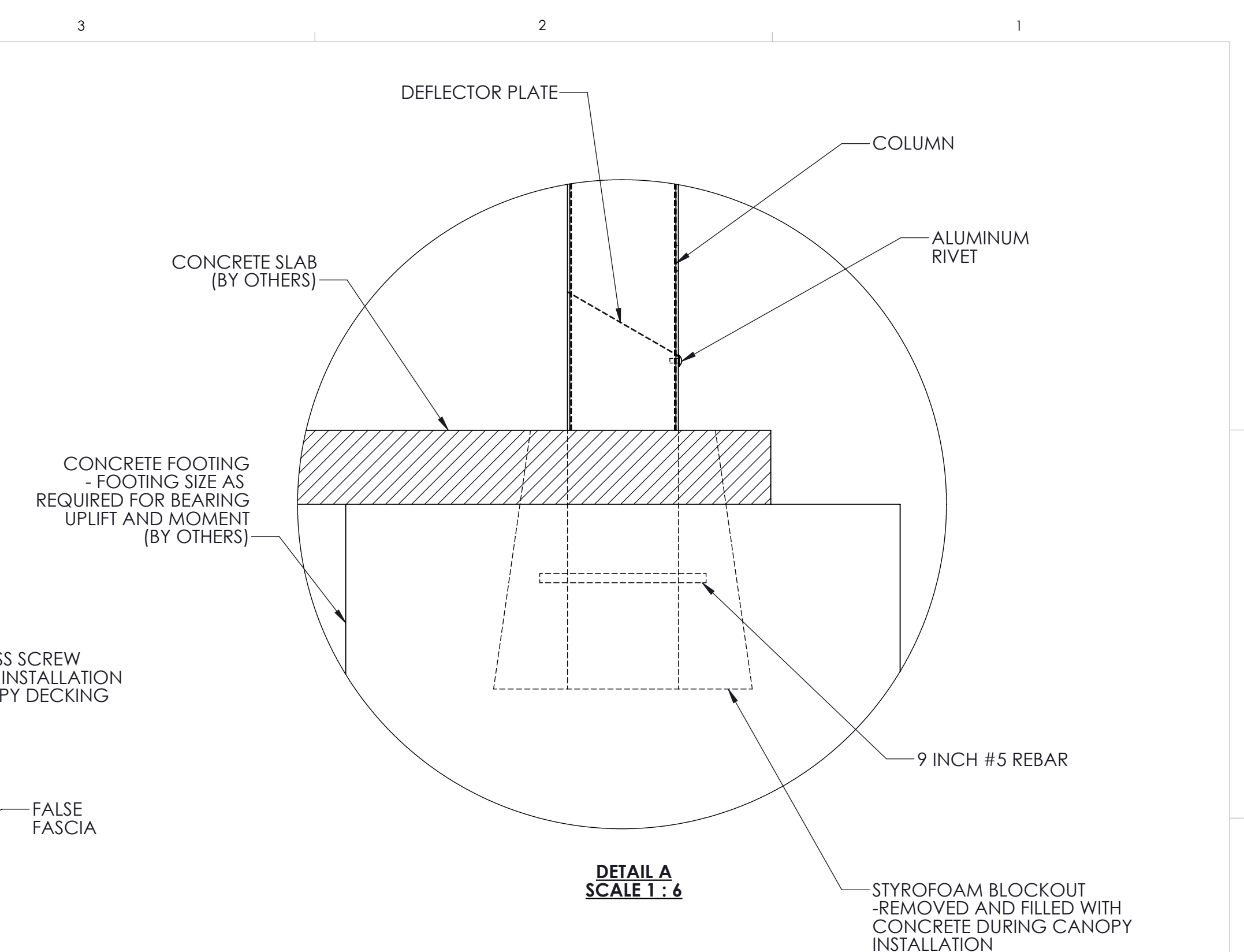

DETAIL A SCALE 1:6

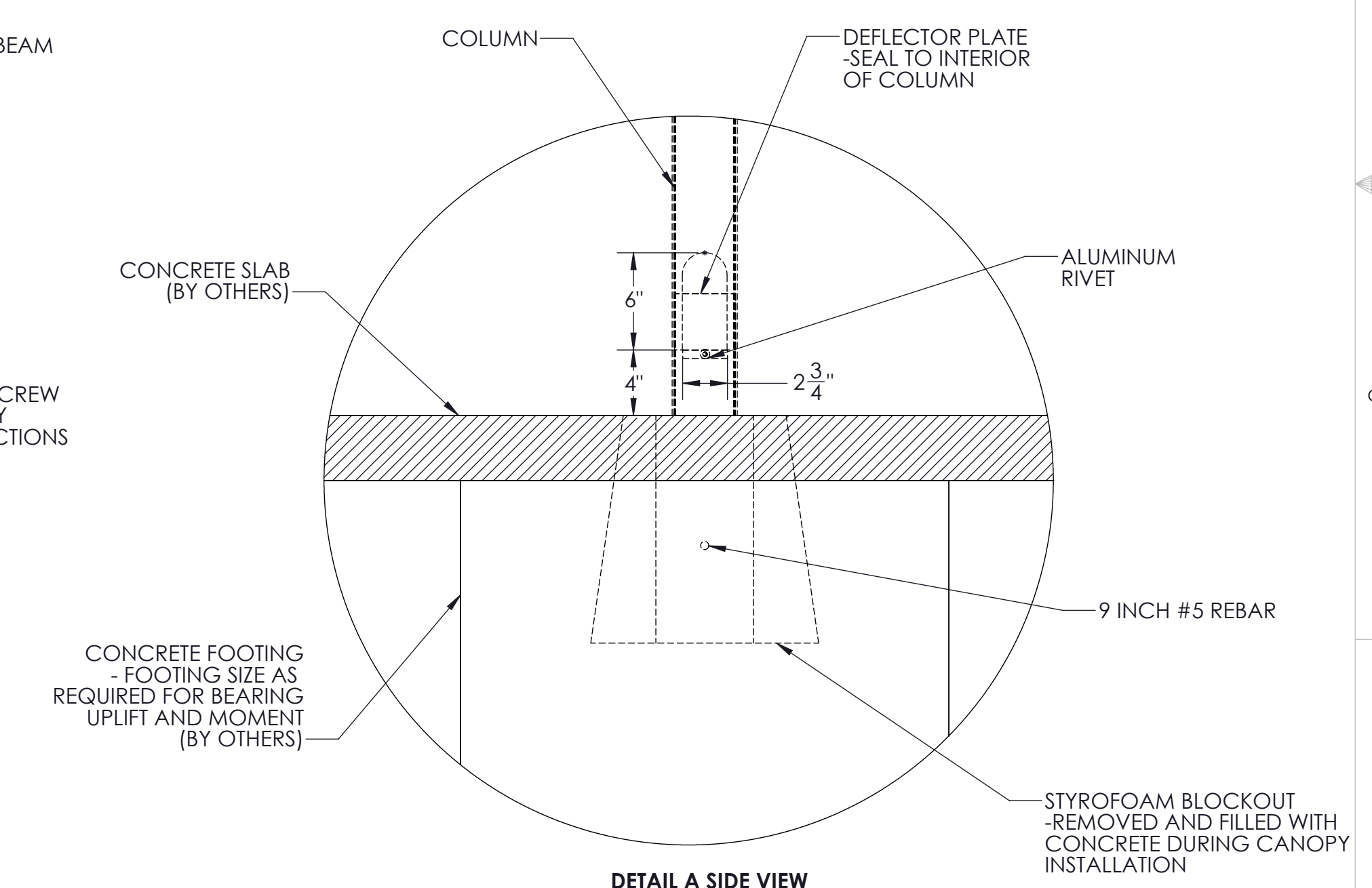

DETAIL A SIDE VIEW SCALE 1:8

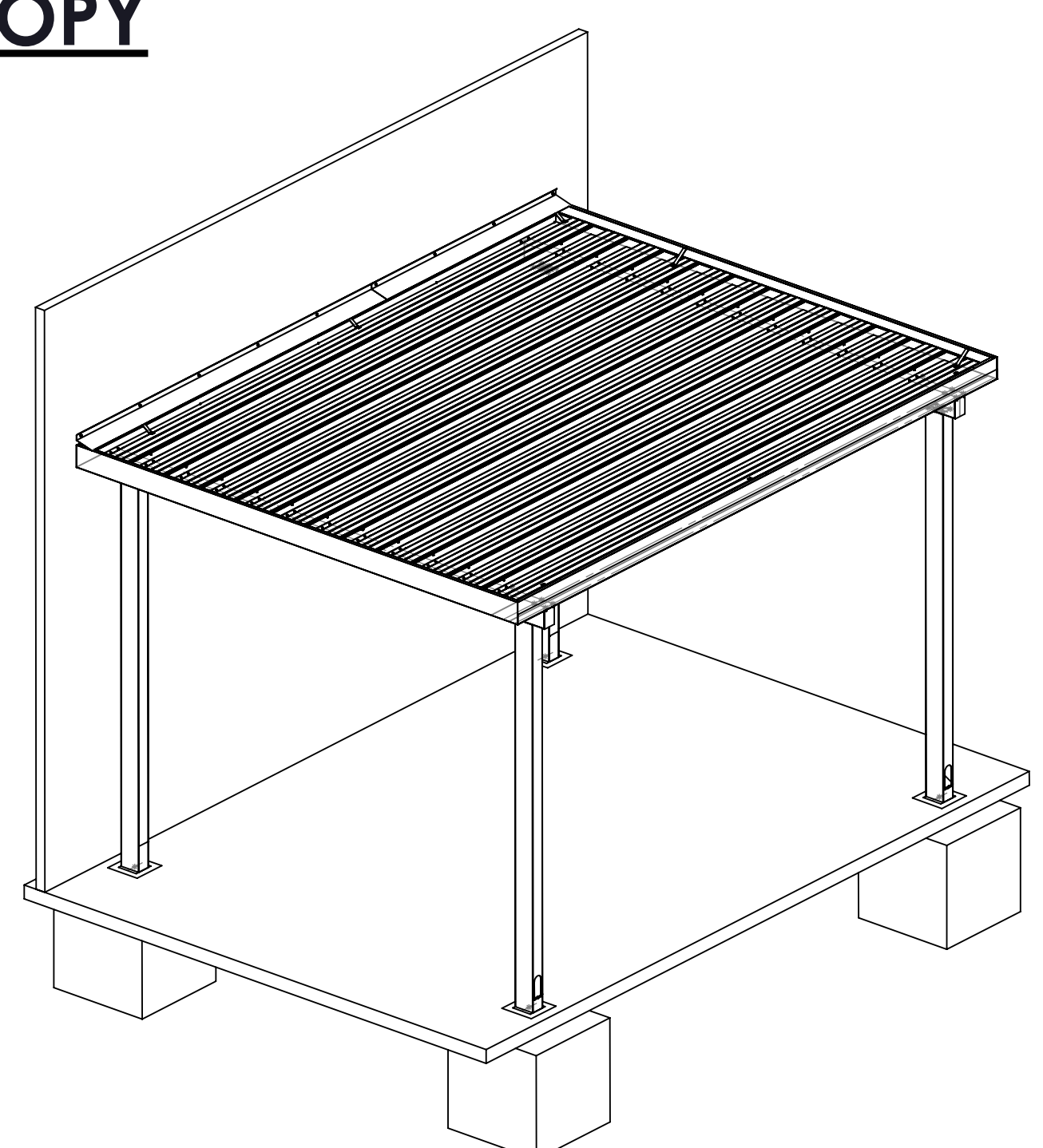

ISOMETRIC VIEW OF CANOPY

SPECIFICATIONS
 Section 107300 - Aluminum Walkway Covers

1.01 General Description of Work:
 A. Work in this section shall include design and fabrication of pre-engineered aluminum canopies.
 B. Canopies are to be fabricated and installed according to approved shop drawings.

1.02 Design Criteria:
 A. International Building Code 2015
 B. ASCE 7-10
 C. Aluminum Design Manual 2015
 D. Local governing codes and standards for site location

1.03 Materials:
 A. All materials shall be extruded from aluminum unless indicated otherwise on the drawing.
 B. Material sizes shall meet or exceed the design criteria on 1.02

1.04 Finishes:
 A. Factory applied baked enamel to comply with AAMA 2603
 B. Color selected from manufacturers standard colors

1.05 Manufacturers:
 A. Mitchell Metals, LLC - www.mitchellmetals.net - 770-431-7300
 B. Dittmer - www.dittdeck.com - 407-699-1755
 C. See Specifications 2.1-C for conditions of equivalent systems by other manufacturers.

- NOTES:
- [DC] = DRAINING COLUMN (IF APPLICABLE)
 - COLUMN HEIGHT RECOMMENDED NOT TO EXCEED 12'-0" OR WIDTH OF CANOPY, WHICH EVER IS LOWER
 - ALL FASTENERS TO BE 300 SERIES STAINLESS STEEL OR ALUMINUM

JOB NAME:	
Aluminum Walkway Covers	
TITLE:	
LONGWAYS	
REVISION # :	
DATE: 8/16/2017	SHEET 1 OF 1

STAMP