

2 CLUSTER BOX UNIT (CBU) CANOPY

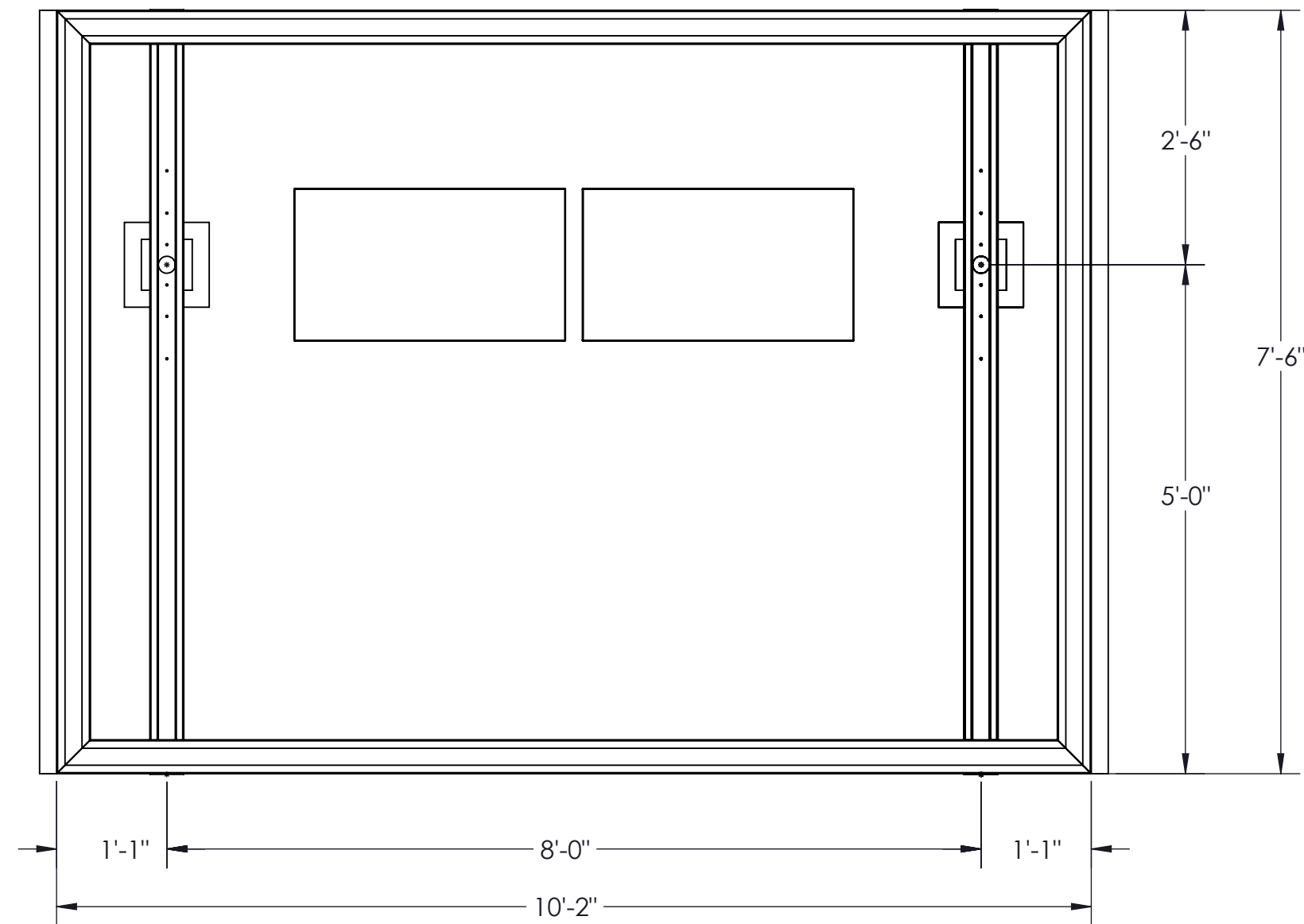

1761 McCoba Drive, Suite A, Smyrna, GA 30080
Phone: (770) 431-7300 Fax: (770) 431-7305

ITEM NO.	PART NUMBER	DESCRIPTION
1		4 x 6 x .150 Column (Draining)
2		4x6 Beam
3		4 inch Welded Bracket
4		4 End Cap
5		4 x 6 x .150 Tube
6		4X6 GUTTER
7		3 x 12 x 0.040 Roll Formed Flat Pan
8	Deflector Plate (4x6 column)	4x6 Deflector Plate



**TOP VIEW - NO DECKING
FRAMING AND GUTTER LAYOUT**

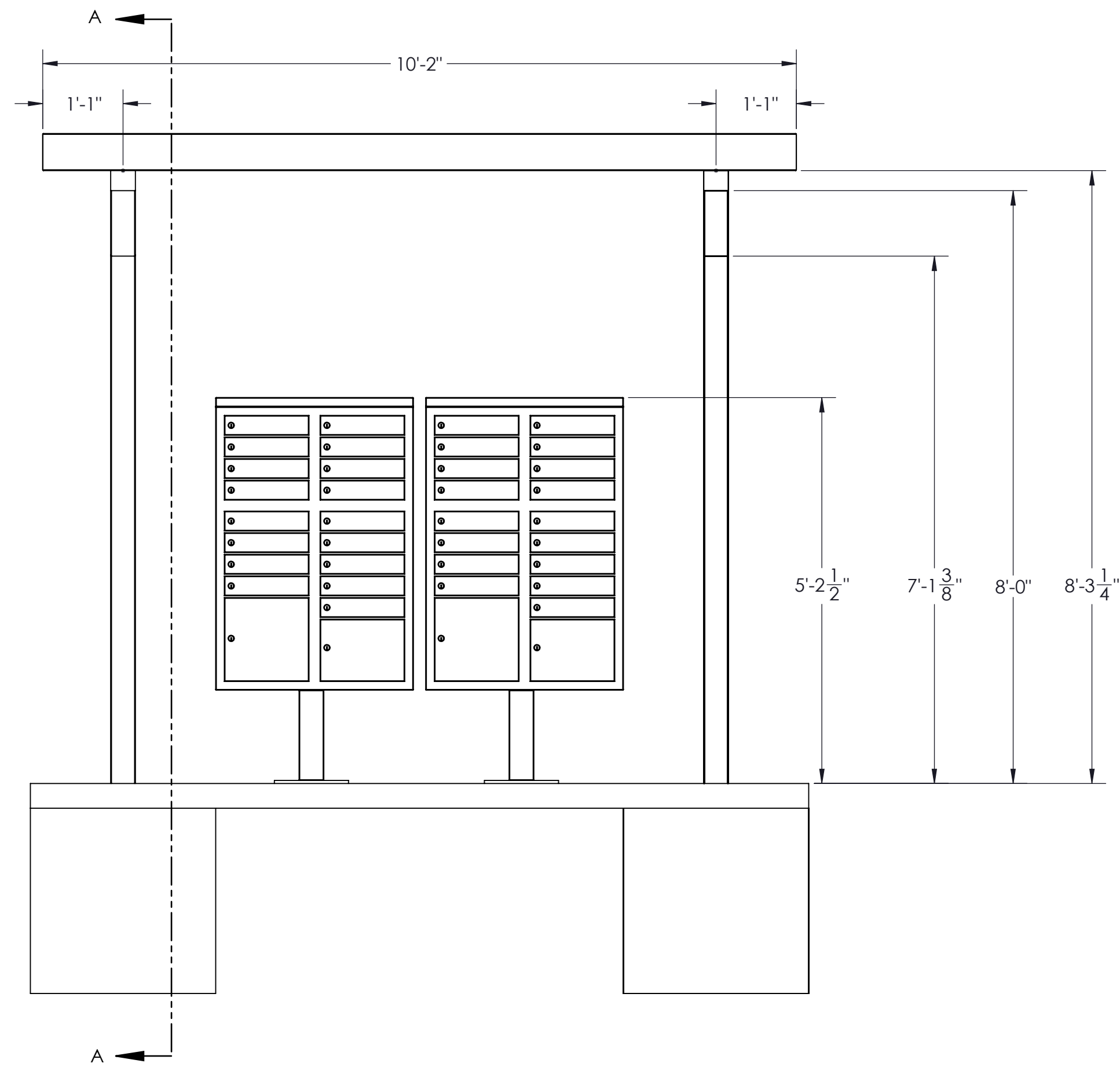

ELEVATION VIEW

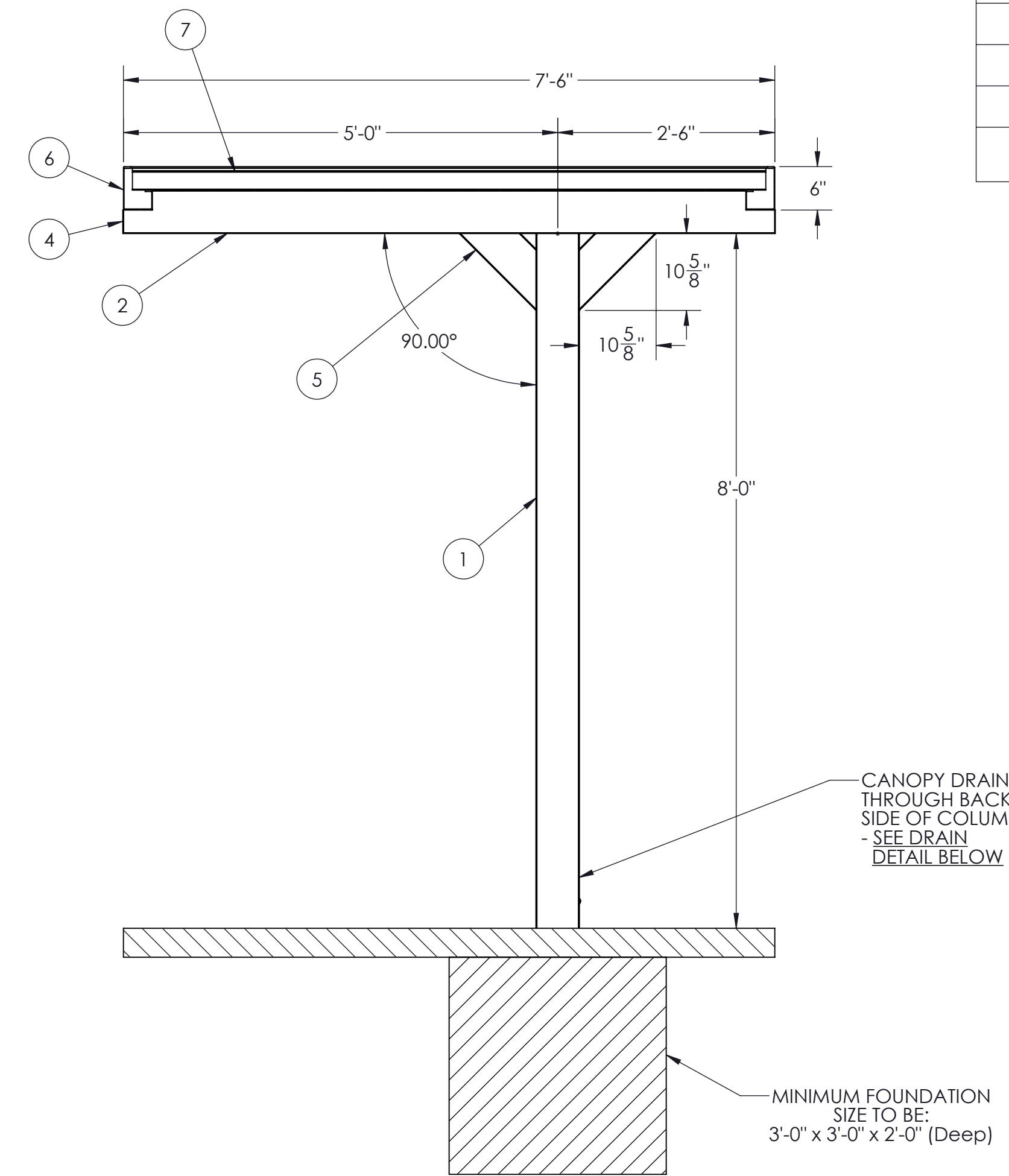

SECTION A-A
SCALE 1 : 16
SECTION VIEW

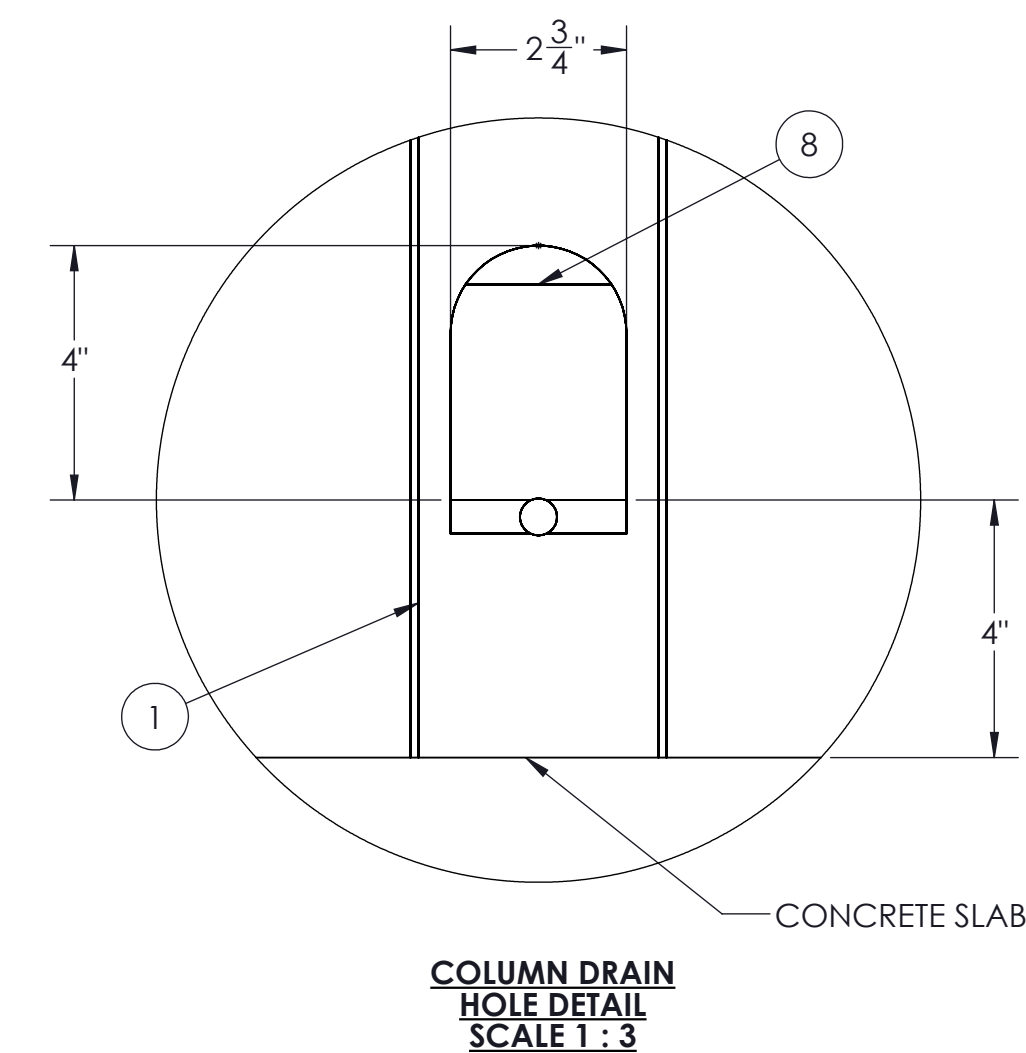

COLUMN DRAIN
HOLE DETAIL
SCALE 1 : 3

GENERAL NOTES:

- 3 mailbox max between columns - configuration can be moved around (EX. 3-3-2 CAN BE 2-3-3 OR 3-2-3)
- Max column height to be 9'-0" (canopy is designed at 8'-0"). Canopy can be lowered to compensate for slope of ground
- Minimum footing size is based on 1500 PSF soil condition
- Canopy designs comply with USPS Developers and Builders Guide
- Reference 2010 ADA Standards or Accessible Design for concrete pad
- Reference Mitchell Metals Cluster Box Unit (CBU) Canopy Cover specification - Section 105500 - Postal Specialties
- DESIGN CRITERIA: IBC 2018, ASCE 7-16, ADM 2015, WIND = 115 mph (max), Exp. = B, Risk Category = II, Ground Snow Load = 30 psf (max), Live Load = 20 psf

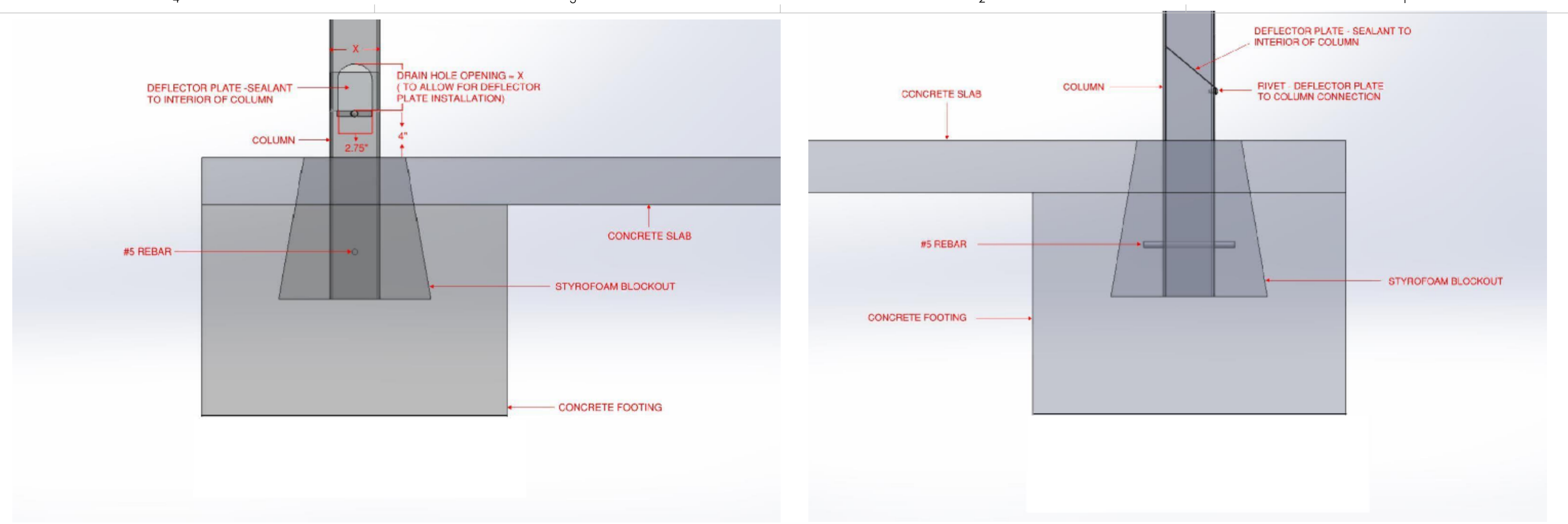

FOUNDATION/BLOCKOUT DETAILS

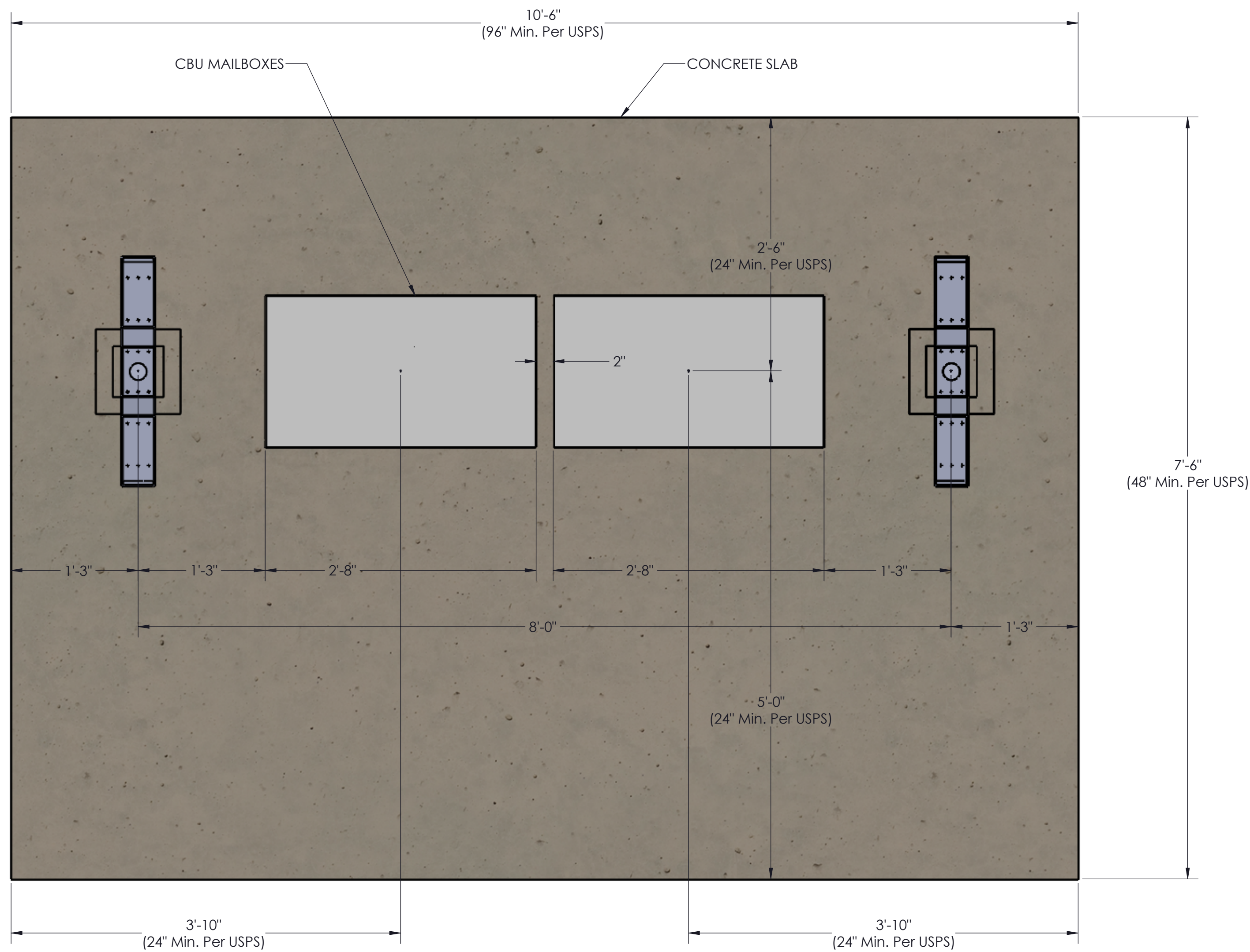

TOP VIEW

COLUMN/MAILBOX/CONCRETE LAYOUT

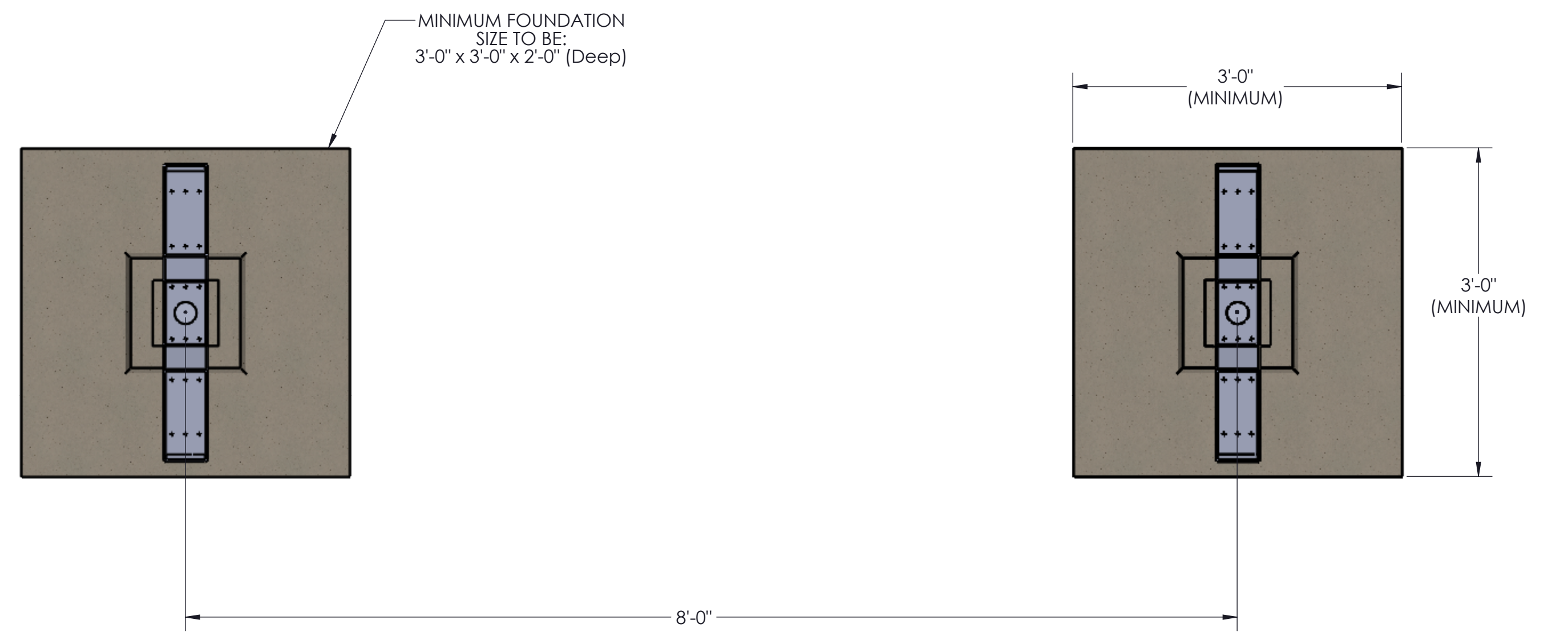

TOP VIEW
FOOTING LAYOUT