

7 CLUSTER BOX UNIT (CBU) CANOPY

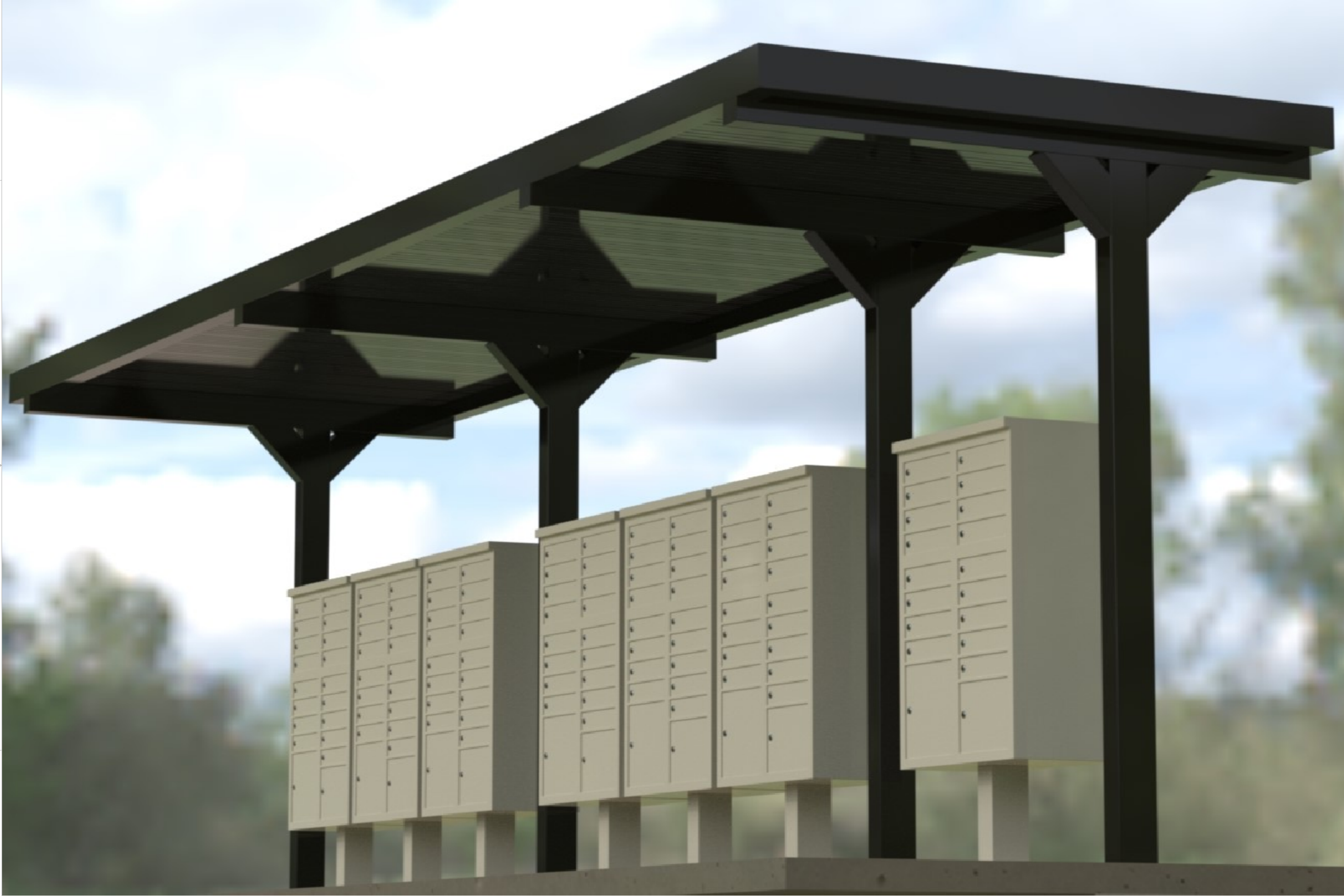

1761 McCoba Drive, Suite A, Smyrna, GA 30080
Phone: (770) 431-7300 Fax: (770) 431-7305

This document is property of Mitchell Metals, LLC. Modifications to this document are prohibited without prior written consent from Mitchell Metals, LLC.

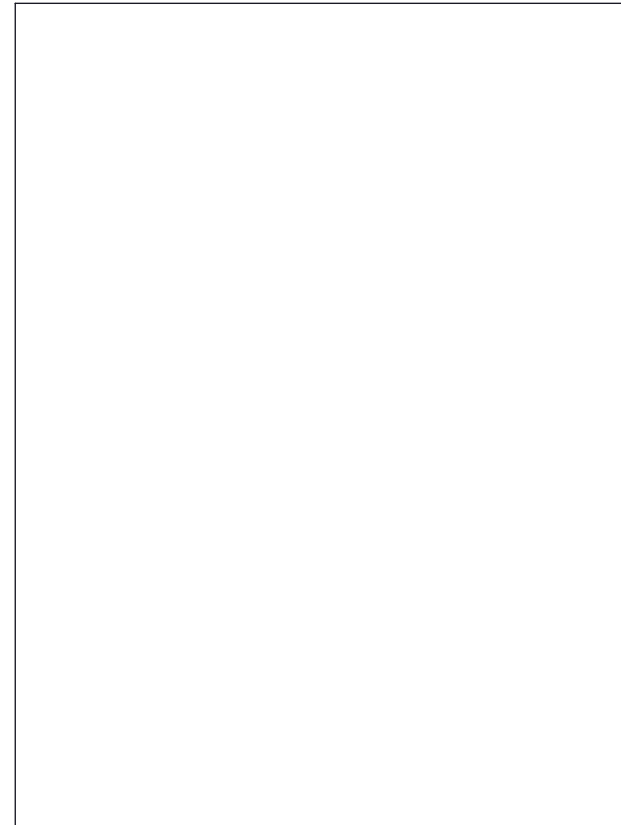



1761 McCoba Drive, Suite A, Smyrna, GA 30080
 Phone: (770) 431-7300 Fax: (770) 431-7305

This document is property of Mitchell Metals, LLC. Modifications to this document are prohibited without prior written consent from Mitchell Metals, LLC.

ITEM NO.	PART NUMBER	DESCRIPTION
1	6063-T6 Aluminum	Column (see page 3 for size)
2	6063-T6 Aluminum	Beam (see page 3 for size)
3	0.080" Aluminum	Welded End Cap
4	6063-T6 Aluminum	4X6 GUTTER
5	Aluminum	3 x 12 x 0.032 Roll Formed Flat Pan
6	Deflector Plate	Deflector Plate
7	CBU Mailbox	

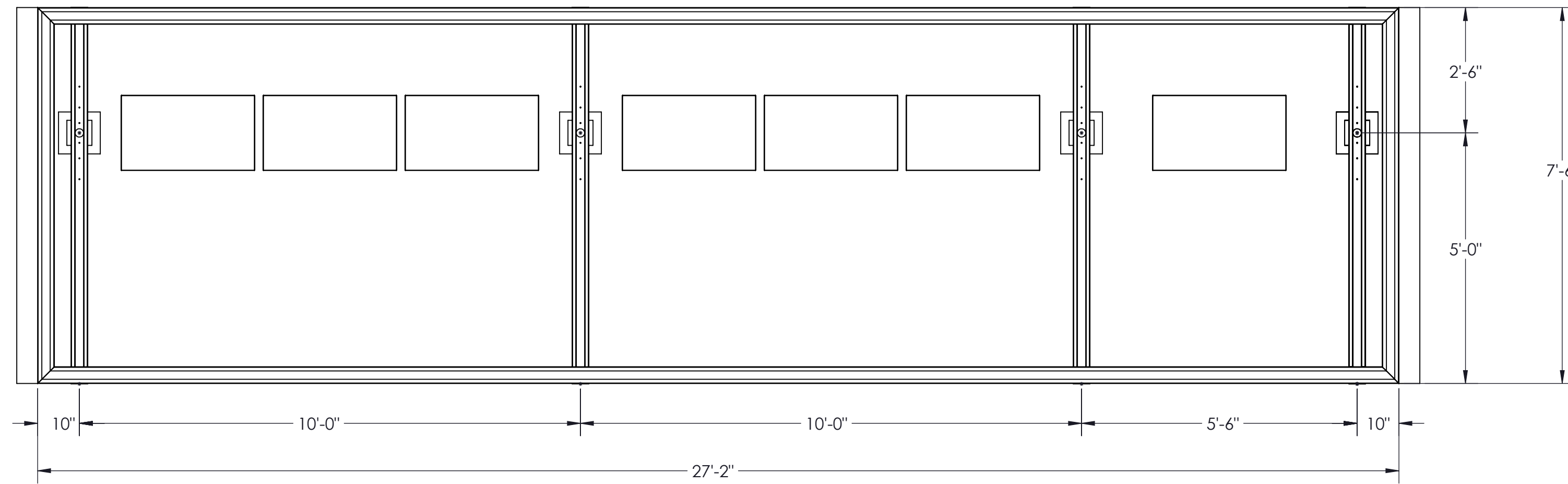

**TOP VIEW - NO DECKING
FRAMING AND GUTTER LAYOUT**

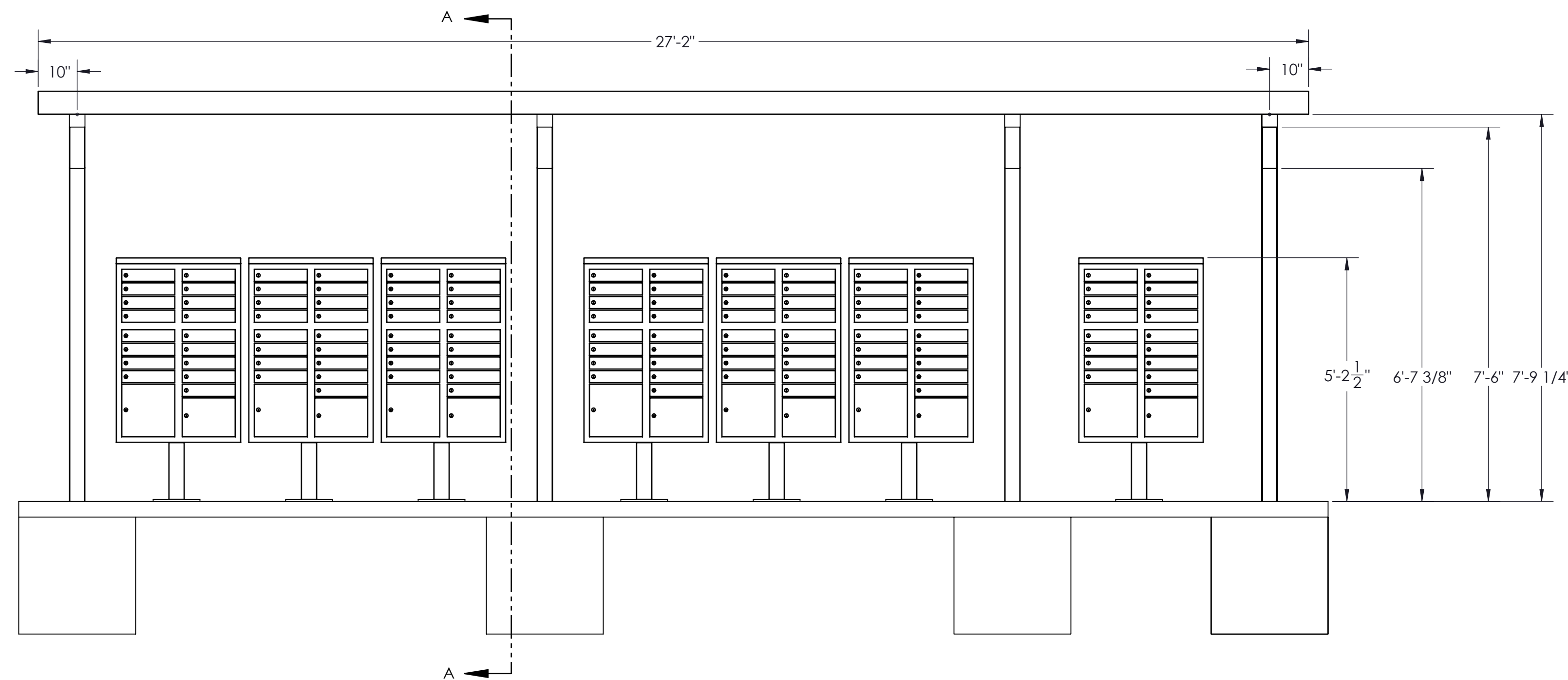

ELEVATION VIEW

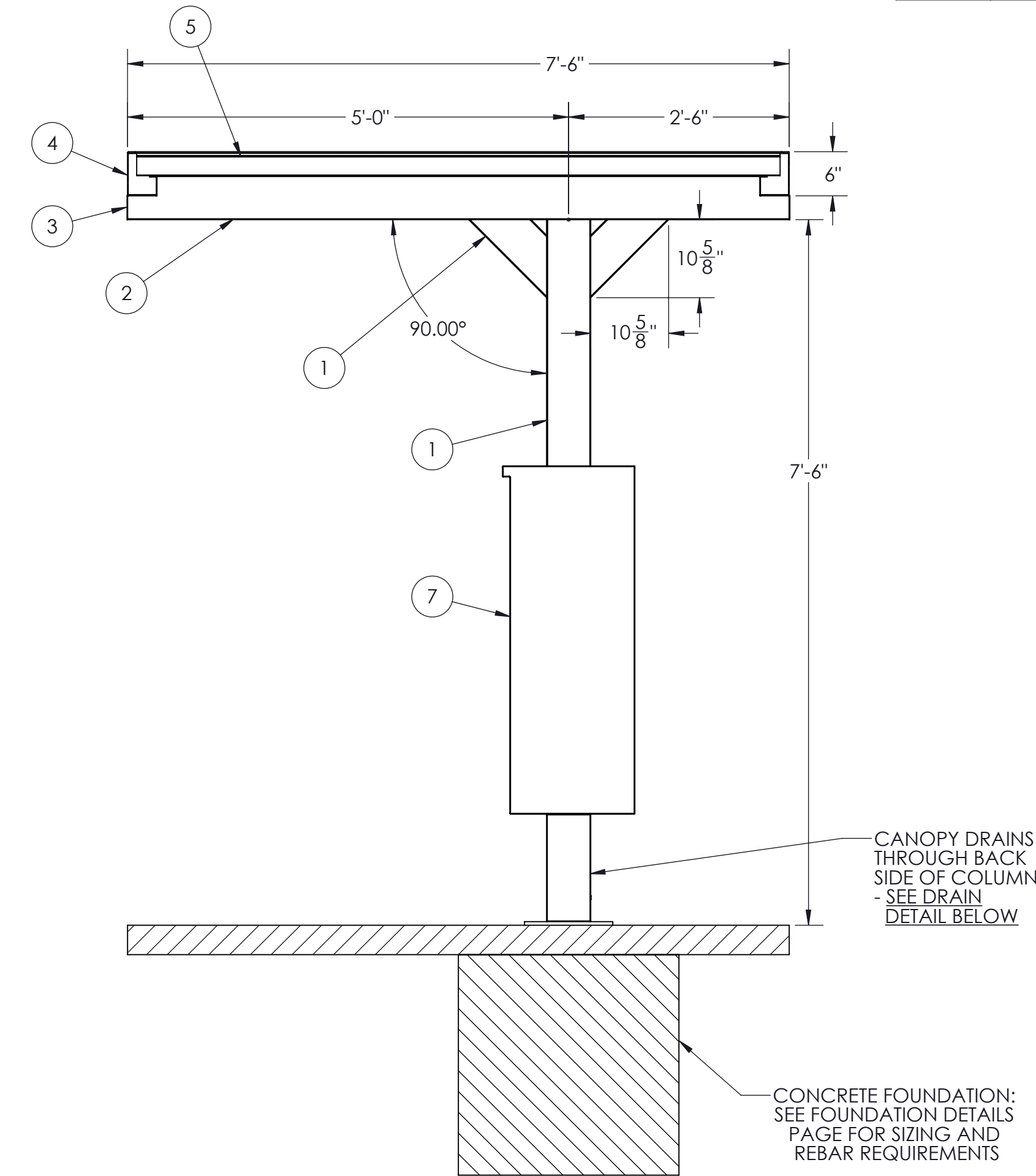

**SECTION A-A
SCALE 1 : 16
SECTION VIEW**

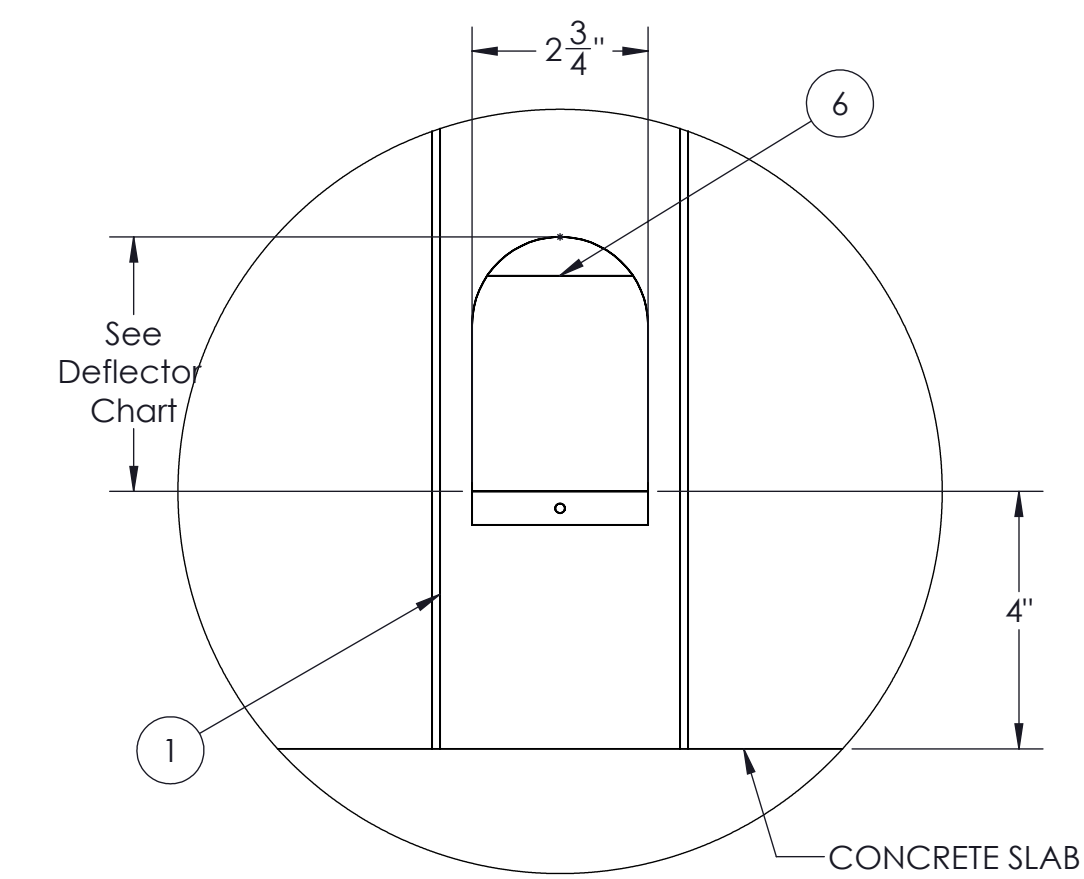

**COLUMN DRAIN
HOLE DETAIL
SCALE 1 : 3**

Deflector Plate Cutout Height	Column Size
4"	4"x6"
6"	6"x6"
6"	6"x8"

STYLE:
7 CLUSTER BOX UNIT (CBU) CANOPY

This document is property of Mitchell Metals, LLC. Modifications to this document are prohibited without prior written consent from Mitchell Metals, LLC.

View before Footing and Blockout Installation



Ver antes de instalar la zapata de concreto

GENERAL NOTES:

- Max column height to be 9'-0". Canopy designed at 7'-6" to bottom of beam above finished concrete slab.
- See Foundation Details Page for concrete foundation design based on project location design criteria.
- Minimum footing size is based on 1500 PSF soil condition.
- Adhere to all local building codes, including layout, foundation design and depth (i.e. frost line depth)
- Canopy designs comply with USPS Developers and Builders Guide.
- Any canopy lighting required is provided by others and may require additional canopy framing to support.
- Reference 2010 ADA Standards for Accessible Design for concrete pad design.
- Reference Mitchell Metals CBU Canopy Cover Specifications - Section 105500 - Postal Specialties
- DESIGN CRITERIA: IBC 2018, ASCE 7-16, ADM 2015, Exposure Category = B, Risk Category = II, Live Load = 20 psf
 - Wind = 115mph (max), Ground Snow Load = 30psf (max) - 4"x6"x0.150" Columns, 4"x6"x0.125" Beams
 - Wind = 140mph (max), Ground Snow Load = 5psf (max) - 6"x6"x0.150" Columns, 6"x6"x0.130" Beams
 - Wind = 170mph (max), Ground Snow Load = 5psf (max) - 6"x8"x0.188" Columns, 6"x6"x0.130" Beams.

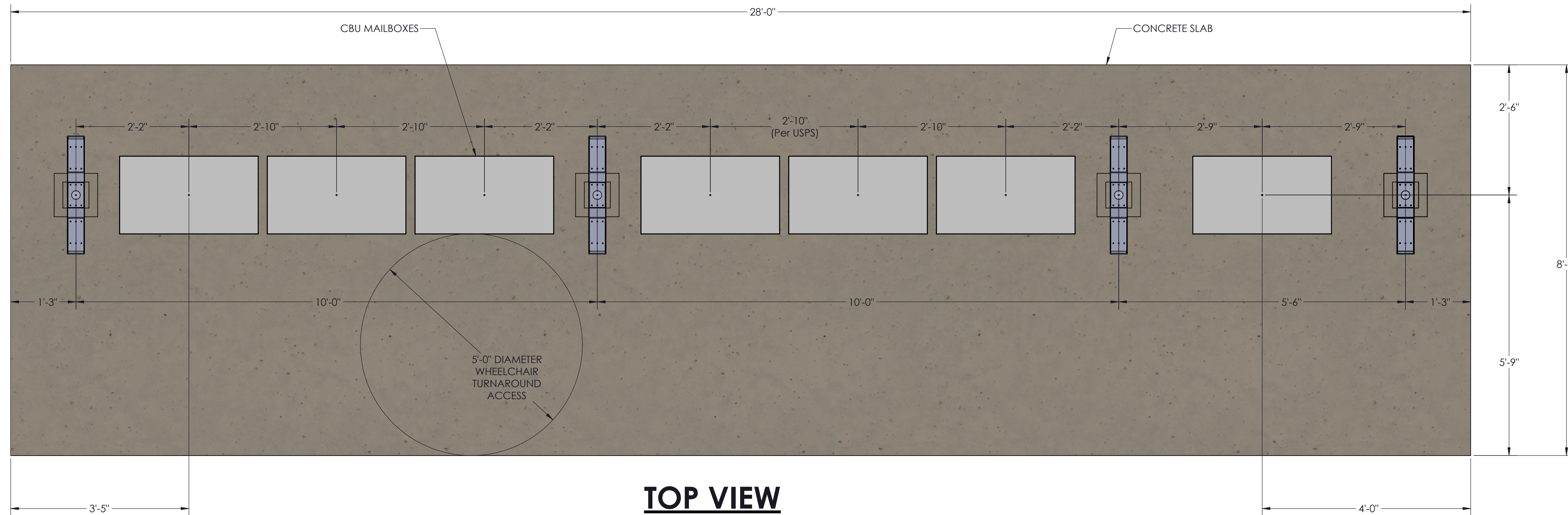

**TOP VIEW
 COLUMN/MAILBOX/CONCRETE LAYOUT**

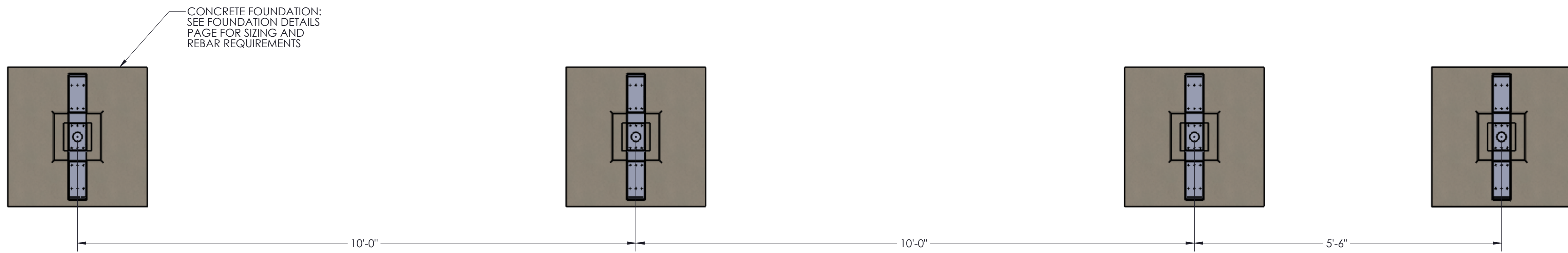

**TOP VIEW
 FOOTING LAYOUT**

STYLE:
7 CLUSTER BOX UNIT (CBU) CANOPY

Standard & B2B CBU Canopy Foundation Design (Up to 115 mph wind, Exp.=B, Risk Category = II, Ground Snow Load = 30psf AND Up to 140 mph wind, Exp.=B, Risk Category = II, Ground Snow Load = 5psf)

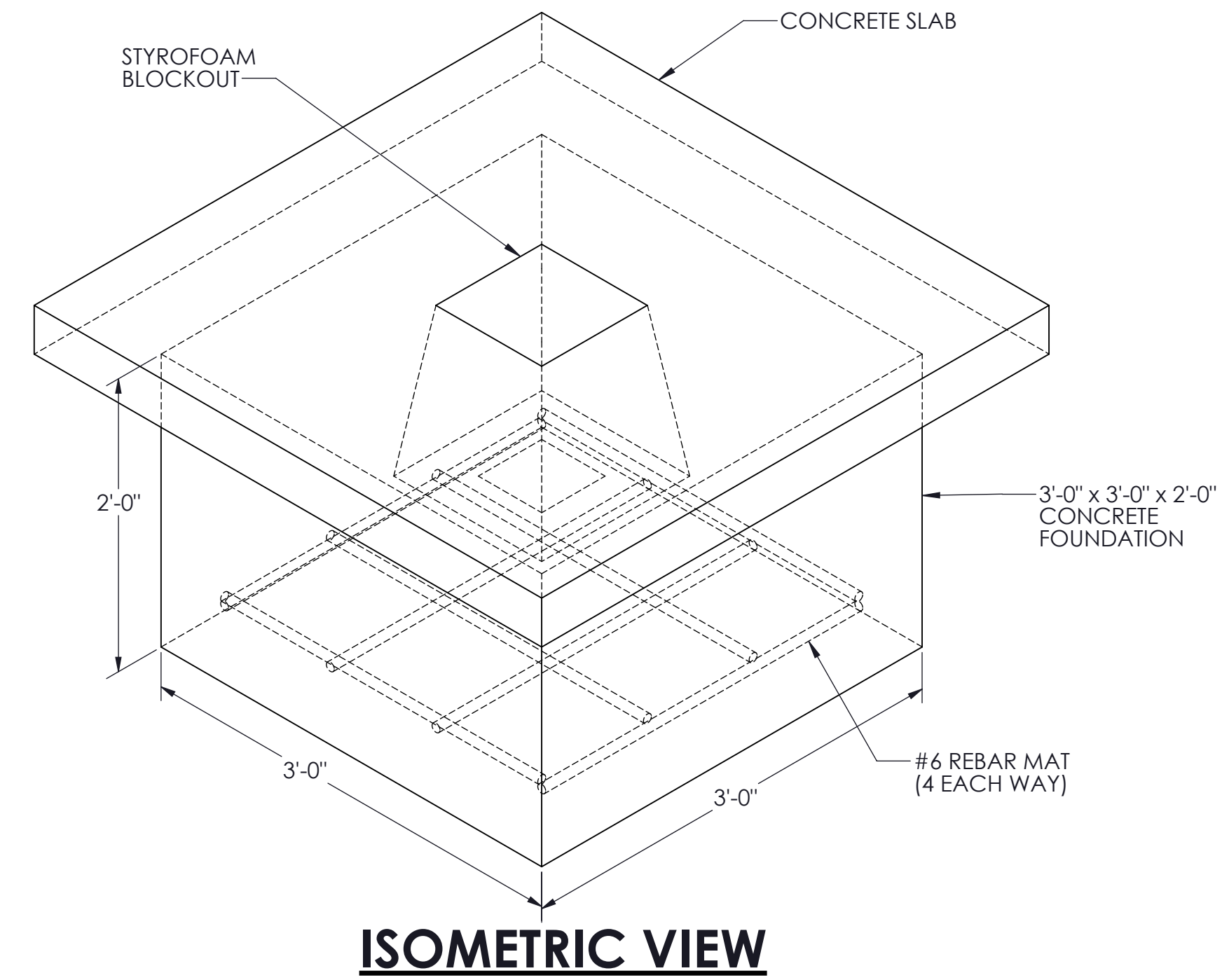

ISOMETRIC VIEW

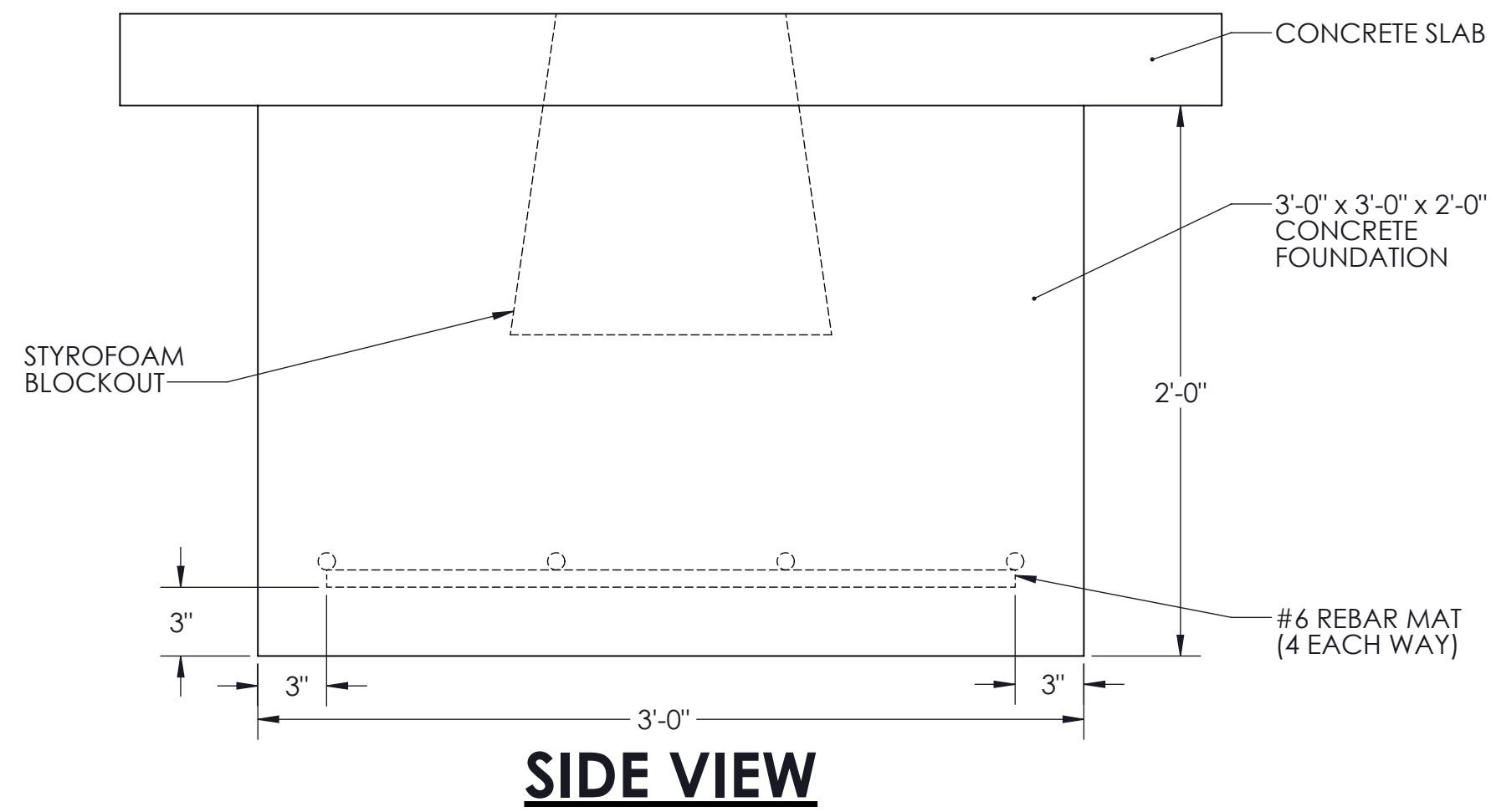

SIDE VIEW

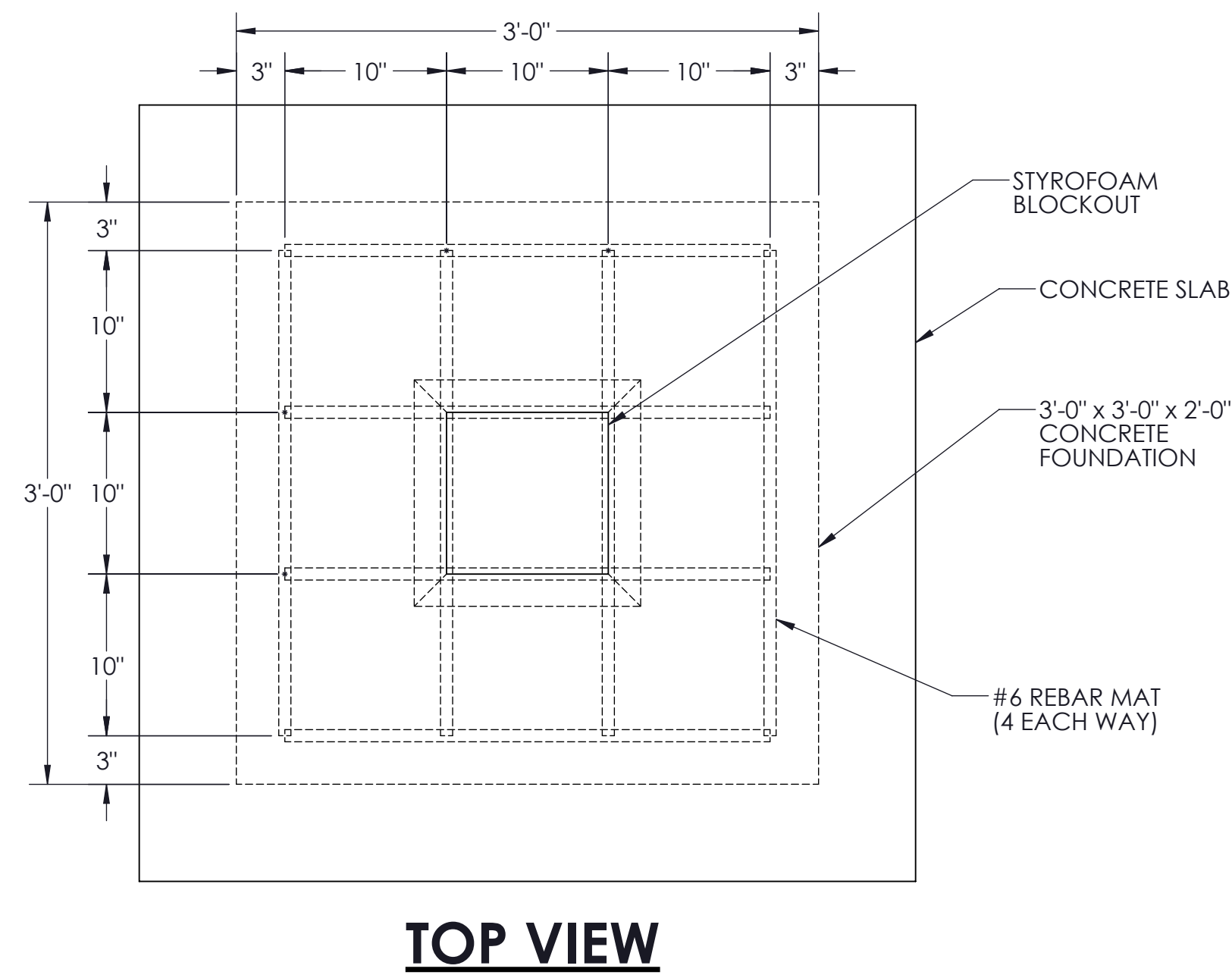

TOP VIEW

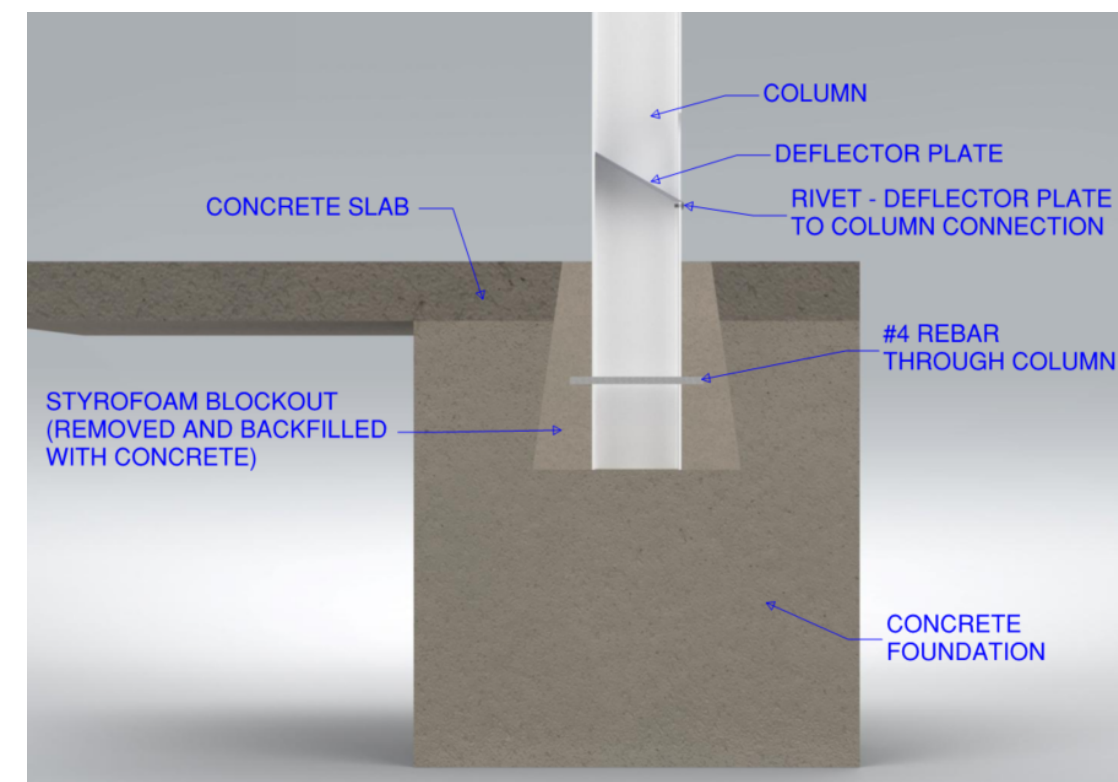

Standard & B2B CBU Canopy Foundation Design (Up to 170 mph wind, Exp.=B, Risk Category = II, Ground Snow Load = 0psf)

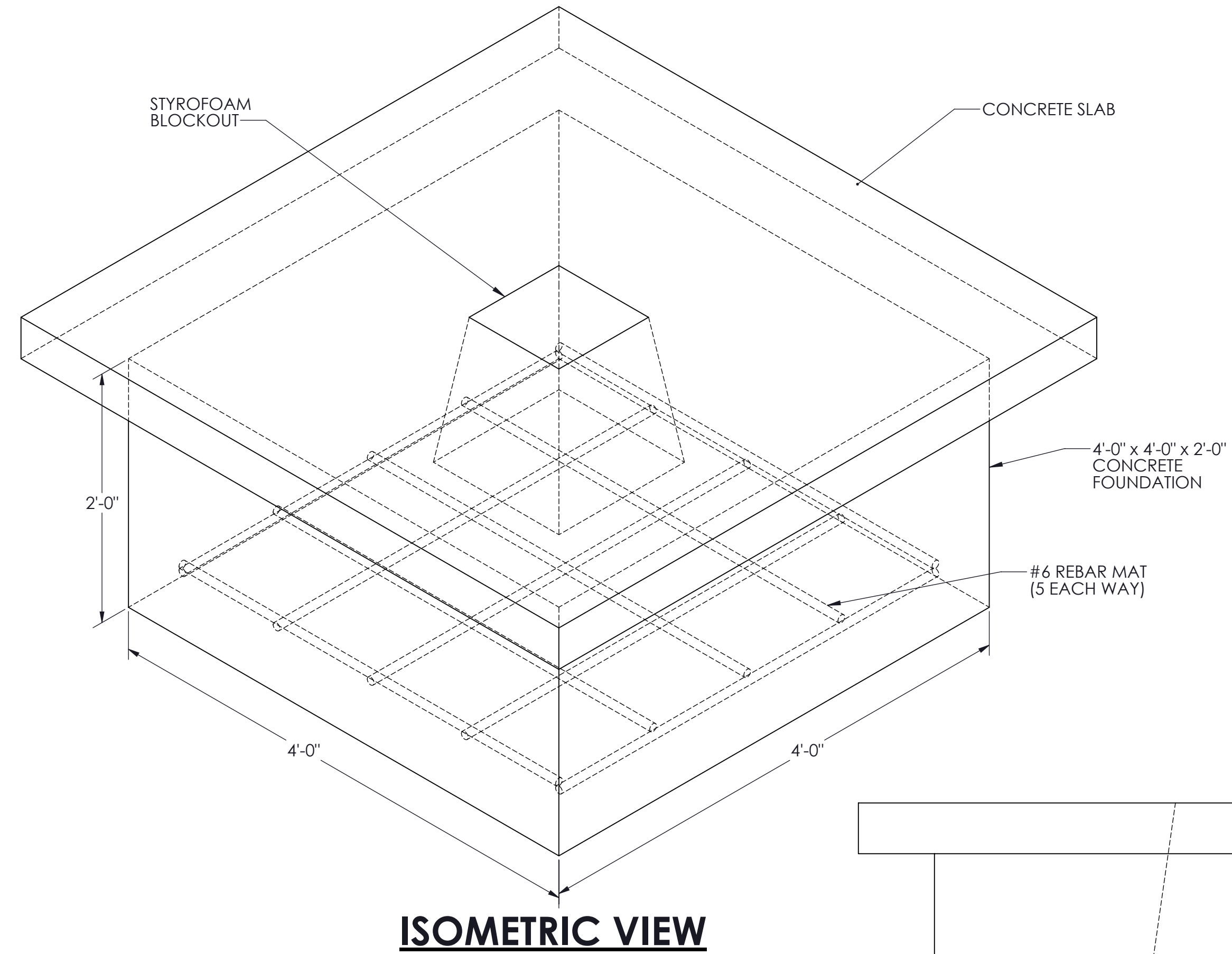

ISOMETRIC VIEW

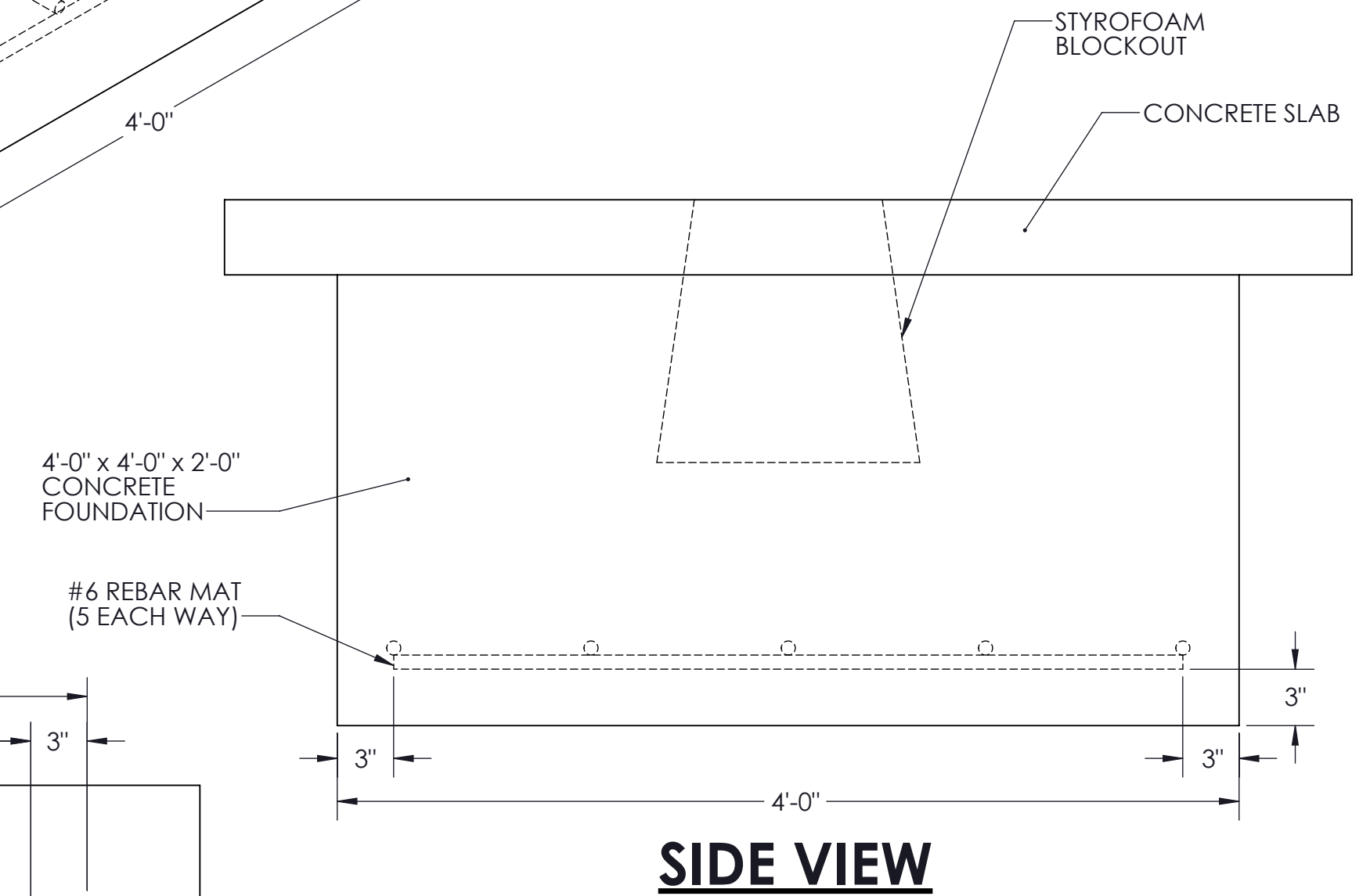

SIDE VIEW

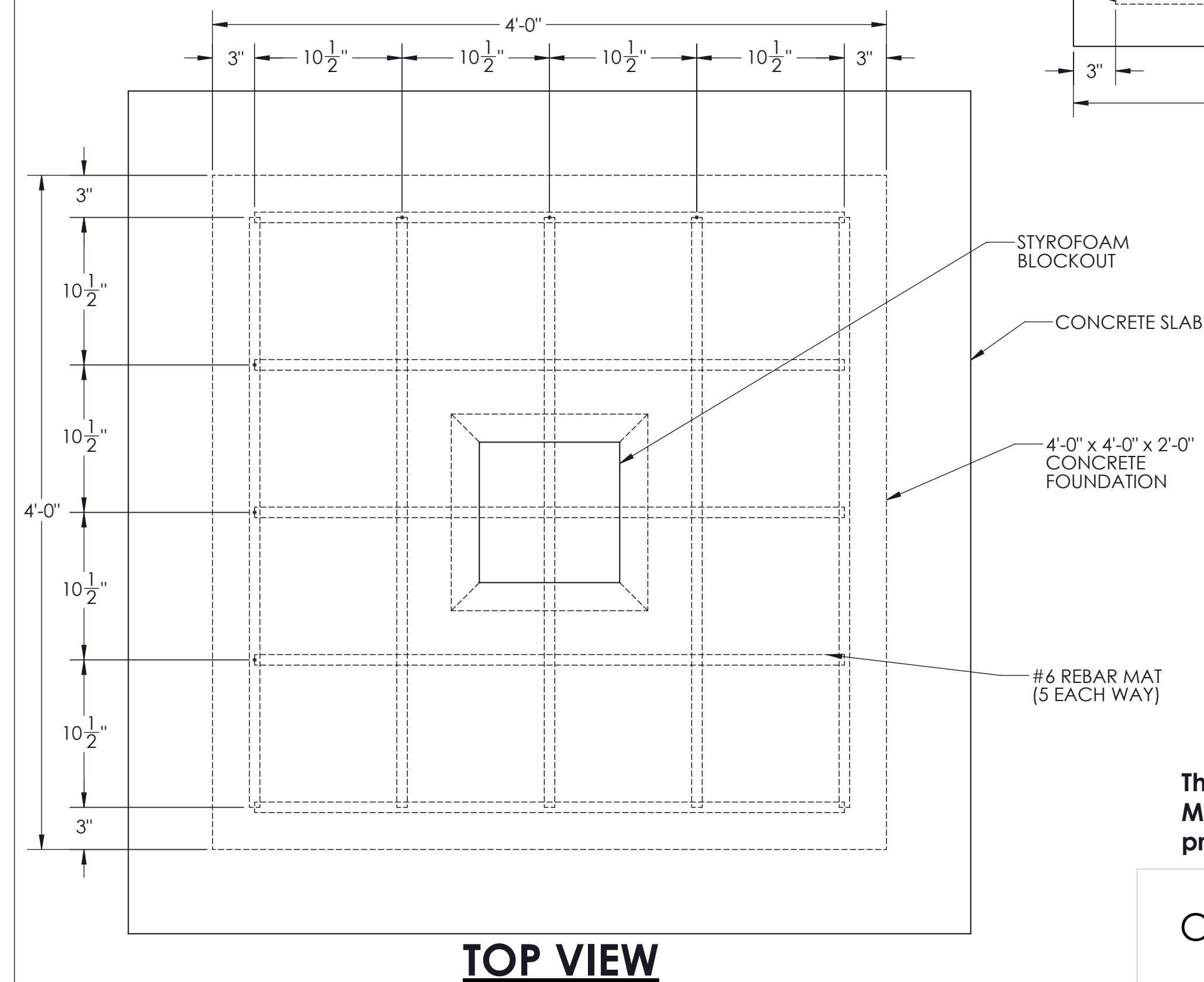

TOP VIEW

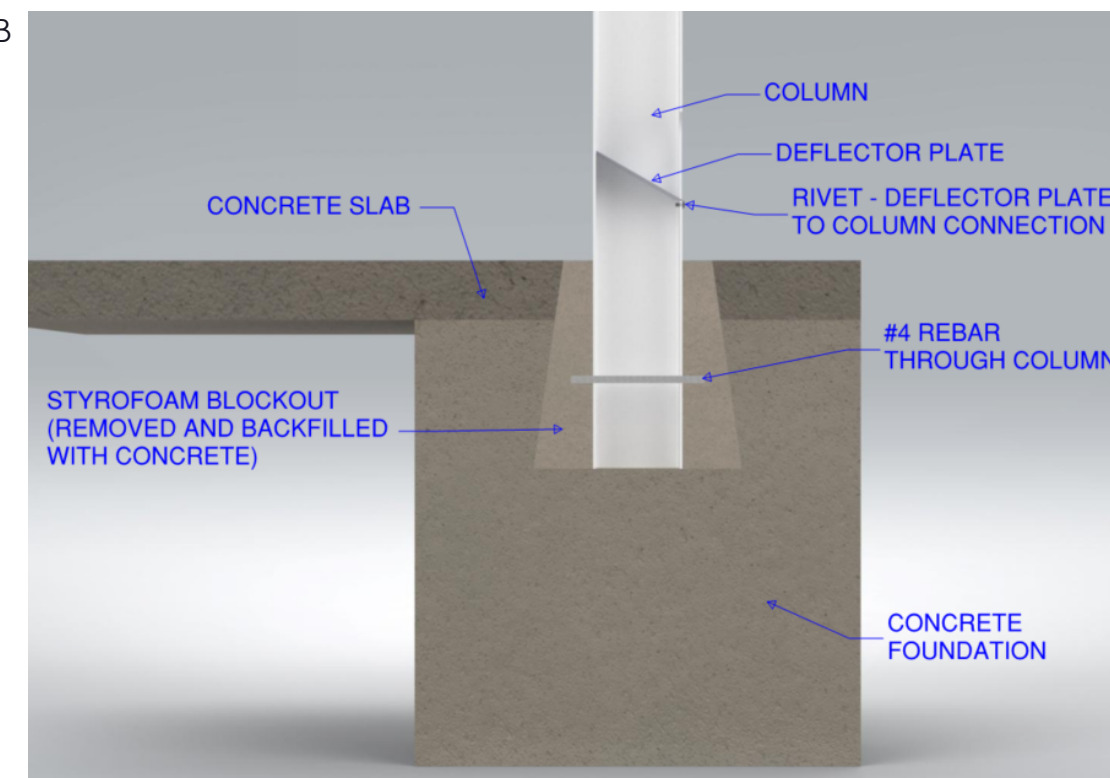

This document is property of Mitchell Metals, LLC. Modifications to this document are prohibited without prior written consent from Mitchell Metals, LLC.

CBU CANOPY FOUNDATION DESIGNS